

IMPERIAL™ ARMOUR

THANATAR SIEGE-AUTOMATA 99590108115

THANATAR SIEGE-AUTOMATA RESIN COMPONENTS LIST

- | | |
|-----------------------------|-----------------------------|
| 1. Body | 19. Left Front Claw |
| 2. Groin | 20. Right Rear Claw |
| 3. Left Foot Flat | 21. Right Front Claw |
| 4. Left Foot Raised | 22. Plasma Flasks x6 |
| 5. Right Foot Raised | 23. Left Hip |
| 6. Right Foot Flat | 24. Right Hip |
| 7. Mauler Bolt Cannon | 25. Left Leg Brace |
| 8. Right Forearm | 26. Right Leg Brace |
| 9. Left Upper Leg | 27. Left Leg Piston x2 |
| 10. Right Upper Leg | 28. Right Leg Piston x2 |
| 11. Helix Plasma Mortar | 29. Left Piston Support x2 |
| 12. Mortar Containment Ring | 30. Right Piston Support x2 |
| 13. Shoulders x2 | 31. Mortar Mount |
| 14. Right Lower Leg | 32. Elbow Joint 1 |
| 15. Left Lower Leg | 33. Elbow Joint 2 |
| 16. Bolt Cannon Ammo Feed 1 | 34. Shin Guard x2 |
| 17. Bolt Cannon Ammo Feed 2 | 35. Waist |
| 18. Left Rear Claw | |

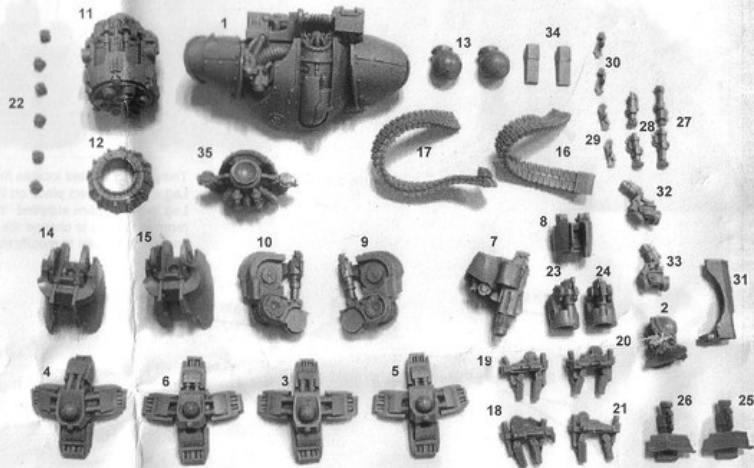

This kit contains all the pieces required to build the Thanatar Siege-Automata
To glue the resin pieces together and to plastic kit parts
use Citadel Super Glue.

NOTE: We have cast this kit using the most advanced techniques
and the best quality resin, but due to the nature of the casting process your
model may contain very slight air bubbles. These can easily be filled with
model filler or super glue. Any slight warpage of thin parts can easily be
corrected by immersing the part in hot tap water for about 1 minute then
carefully bending it back into shape.

THIS IS NOT A TOY

Not suitable for children under 15 years of age.

WARNING: Resin dust can be harmful if inhaled. Always wear a dust
mask or respirator when sanding or sawing resin parts.

The copyright on the model designs and components within
this box is the exclusive property of Games Workshop Ltd.
Copyright Games Workshop Ltd., 2014. All rights reserved.

Forge World, Games Workshop, Willow Road, Lenton, Nottingham, NG7 2WS, UK. Tel. 0044 (0)115 916 8177

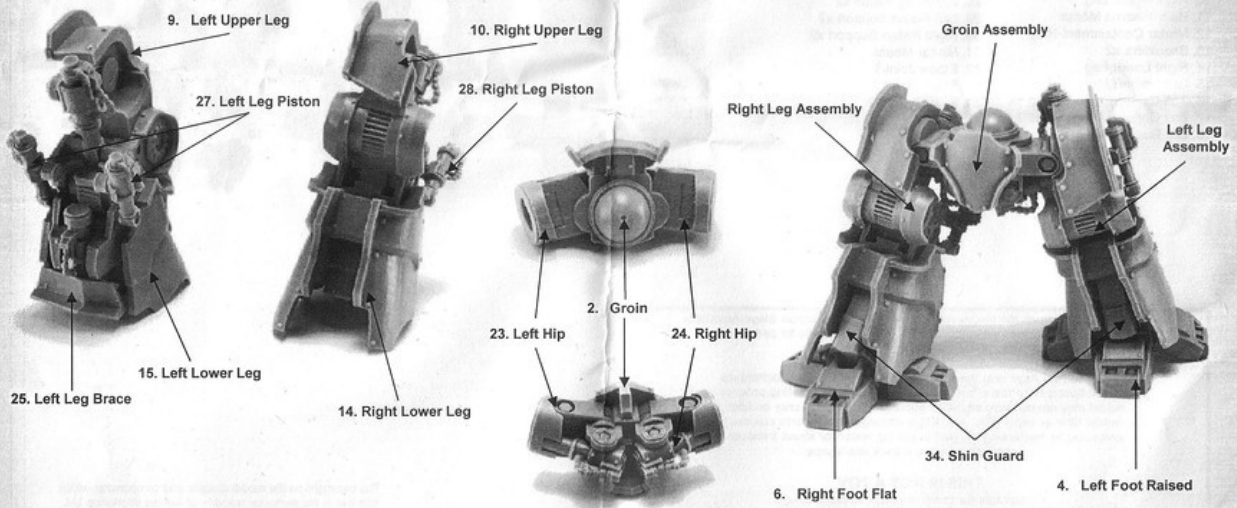
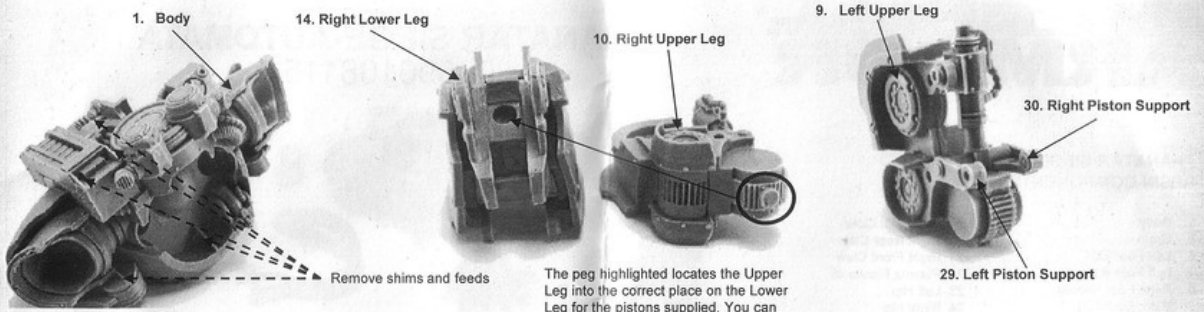

The Thanatar comes with two spare feet to allow different poses.

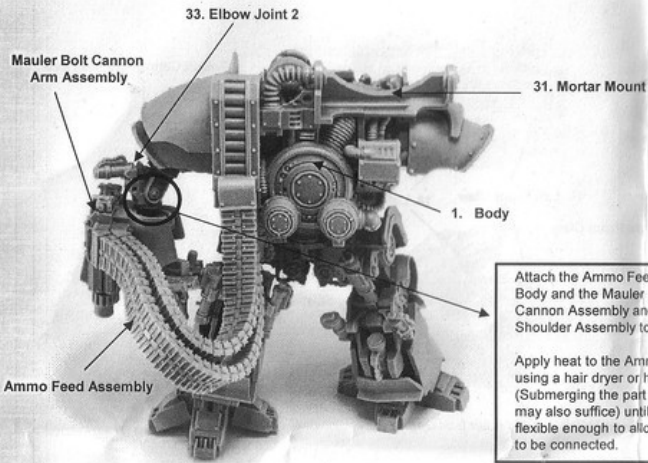

Attach the Ammo Feeds to the Body and the Mauler Bolt Cannon Assembly and attach the Shoulder Assembly to the Body .

Apply heat to the Ammo Feeds using a hair dryer or hot air gun (Submerging the part in hot water may also suffice) until they are flexible enough to allow the elbow to be connected.

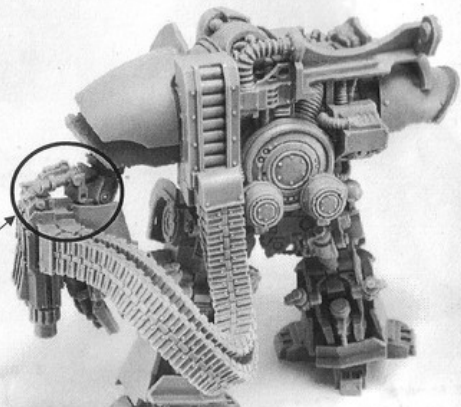

35. Waist

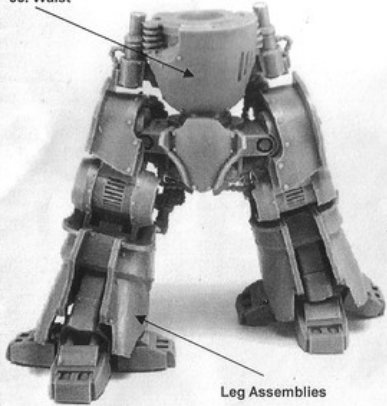

Leg Assemblies

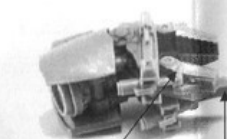

20. Right Rear Claw

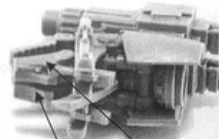

18. Left Rear Claw



21. Right Front Claw

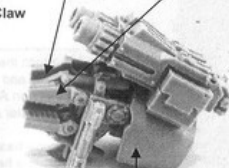

19. Left Front Claw

8. Right Forearm

7. Mauler Bolt Cannon

17. Bolt Cannon Ammo Feed 2

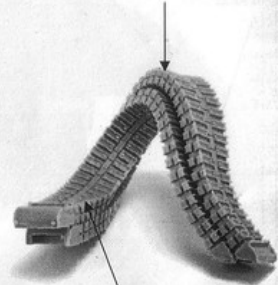

16. Bolt Cannon Ammo Feed 1

13. Shoulder

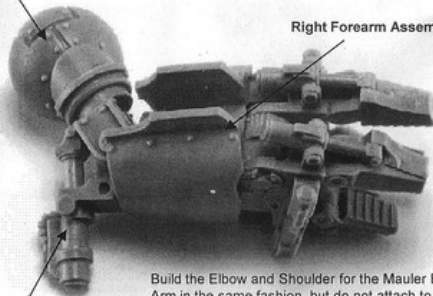

Right Forearm Assembly

32. Elbow Joint 1

12. Mortar Containment Ring

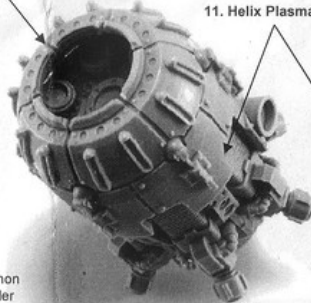

11. Helix Plasma Mortar

22. Plasma Flasks x6

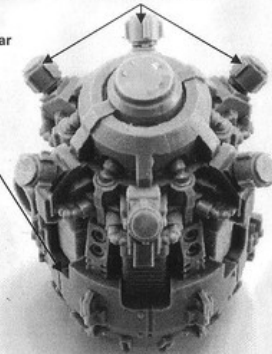

Build the Elbow and Shoulder for the Mauler Bolt Cannon Arm in the same fashion, but do not attach to the Mauler Bolt Cannon Assembly

Note: Elbows can be used on either arm, but the Cannon Ammo Feeds are shaped to fit using Elbow Joint 2 on the Mauler Arm posed as in these instructions. Other poses are possible but they will require more significant heat bending of the Ammo Feeds.