

NECRON SERAPTEK HEAVY CONSTRUCT

Armed with a pair of formidable heavy weapons, the Necron Seraptek Heavy Construct can unleash energies capable of disintegrating both organic and machine matter. Those rare few among the Imperium who have survived an encounter with a Seraptek have testified to its unnatural speed and agility, and the near-total dominance it seems to hold over the lesser Canoptek-class constructs within its sight. None know to what end this colossus of war was originally intended to serve, though few can deny the devastation it wreaks once it takes to the battlefield.

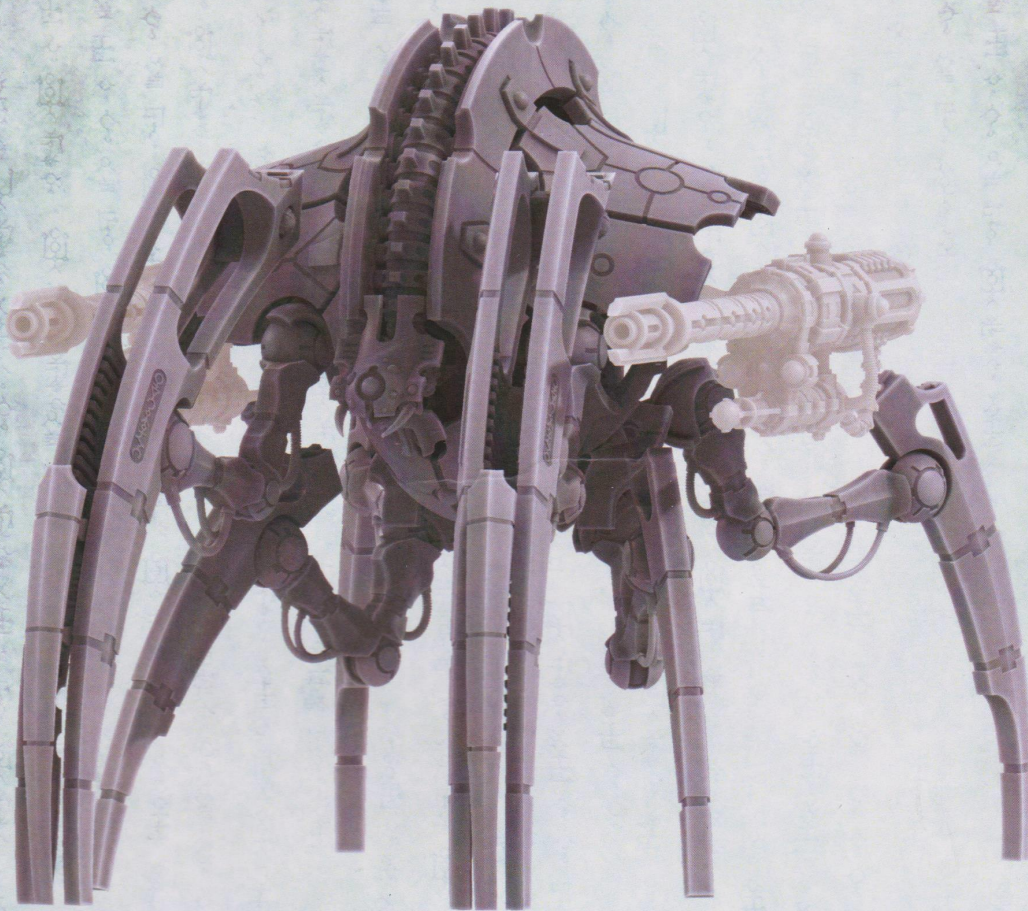

THIS IS NOT A TOY

Not suitable for children under 15 years of age.

WARNING: Resin dust can be harmful if inhaled. Always wear a dust mask or respirator when sanding or sawing resin parts.

www.forgeworld.co.uk



COMPONENTS

Before assembly, check that none of the components are missing.

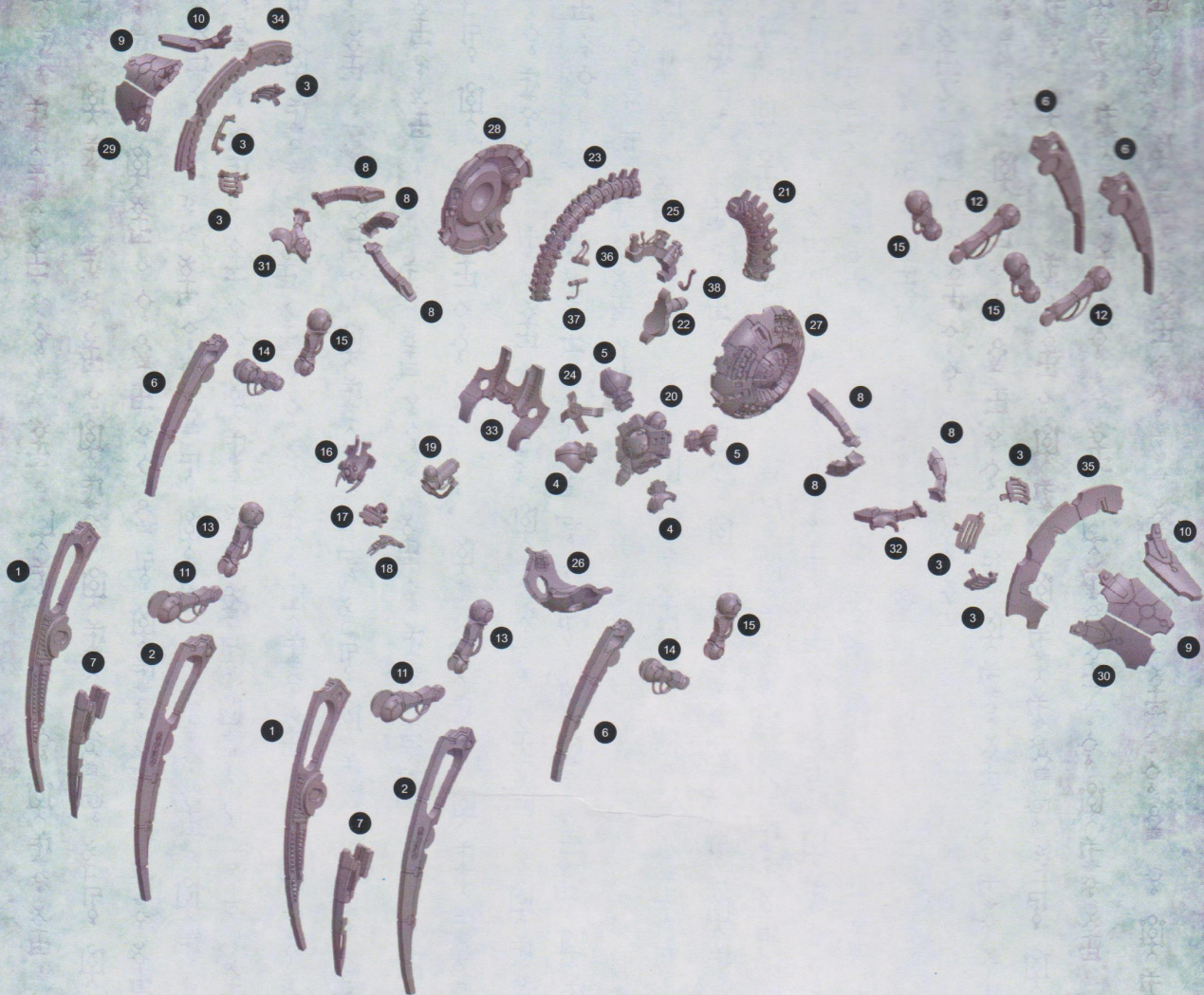

If you need to contact the Forge World Customer Service team regarding this model, you can get in touch via email – forgeworld@gwplc.com – or call:

0115 900 4995 within the UK

011 44 115 900 4995 from the USA and Canada









0011 44 115 900 4995 from Australia

00 44 115 900 4995 from Europe and the rest of the world.

1. Right Lower Arm x2
2. Left Lower Arm x2
3. Thermal Venting Plate x6
4. Front Hip Socket x2
5. Rear Hip Socket x2
6. Lower Leg x4
7. Blade x2
8. Weapon Support Arm x6
9. Central Shoulder Plate x2
10. Rear Shoulder Plate x2
11. Fore Arm x2
12. Rear Leg Middle x2
13. Arm Upper x2
14. Front Leg Middle x2
15. Leg Upper x4
16. Head
17. Lower Head
18. Neck Plating
19. Neck
20. Hips
21. Rear Spinal Section
22. Lower Spinal Mount
23. Spine
24. Armour Plate Mount
25. Spinal Support
26. Ventral Armour Plating
27. Left Superstructure
28. Right Superstructure
29. Right Shoulder Plate Front
30. Left Shoulder Plate Front
31. Right Weapon Support Arm
32. Left Weapon Support Arm
33. Pelvic Armour Plating
34. Right Spinal Plating
35. Left Spinal Plating
36. Spinal Cable 1
37. Spinal Cable 2
38. Spinal Cable 3



Assembly Legend

Parts for Assembly	
Note	
Glue Contact Area	
Shim for Removal	
Option	
Reverse Angle	
Do Not Glue	
Insert	
Component Highlight	

Preparing the Model for Assembly

Before assembling the model, wash each part thoroughly with an abrasive brush, such as a toothbrush, to remove any model release agent that may still be on the surface of the parts. Then, remove any excess resin such as mould lines, casting gates, vents and shims. For a more detailed guide to working with resin models, go to the Downloads section of the Forge World website.

This kit contains all the pieces required to construct the Necron Seraptek Heavy Construct. To glue the resin pieces together, use Citadel Super Glue.

NOTE: We have cast this kit using advanced techniques and the best quality resin, but due to the nature of the casting process, your model may contain small air bubbles. These can easily be filled with model filler or super glue. Any slight warpage of thin parts can be corrected by immersing the part in hot water for about 1 minute, then bending it back into shape.

1

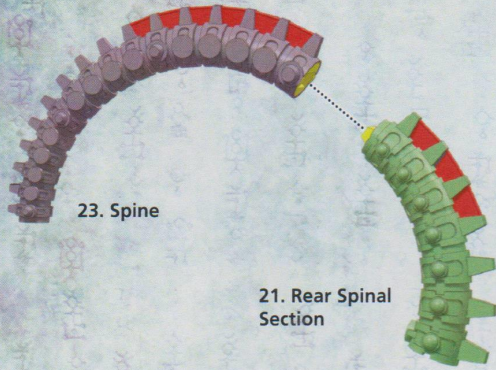

2

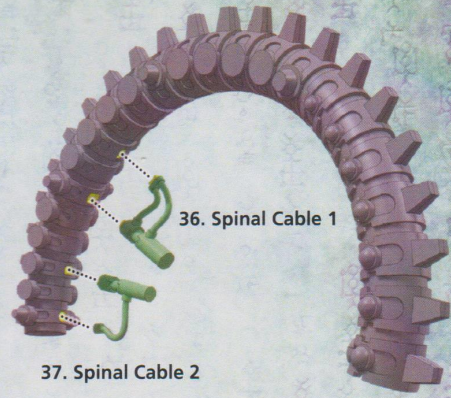

3

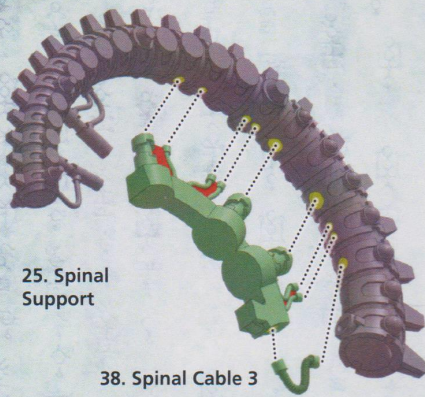

4

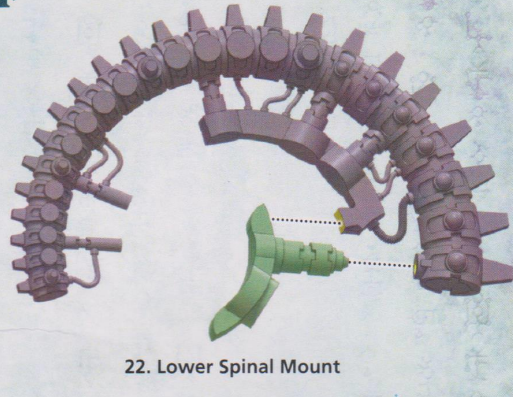

5

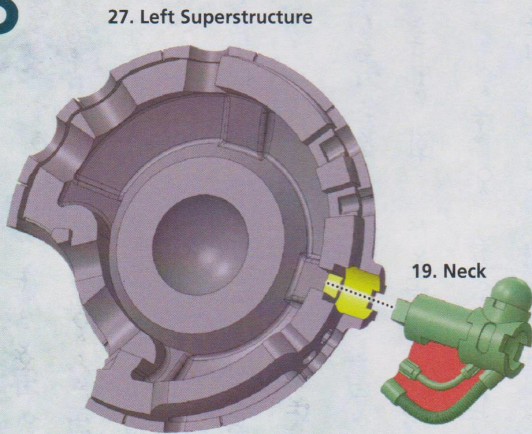

6

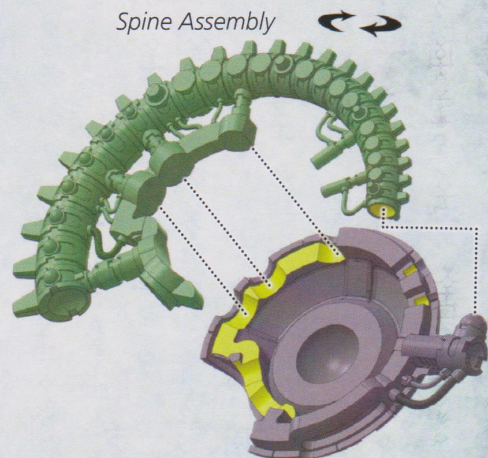

7

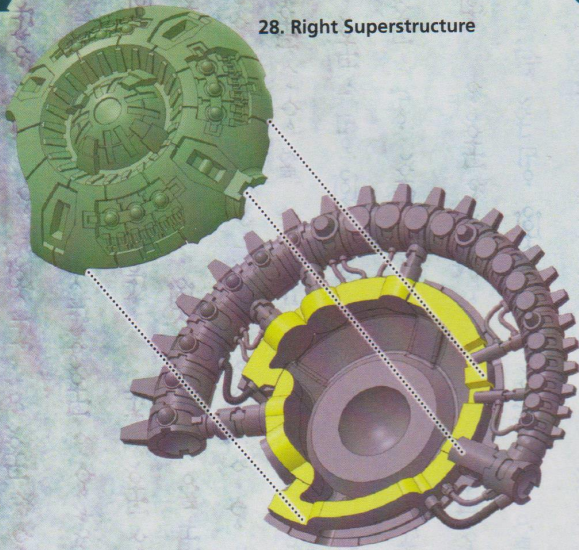

28. Right Superstructure

8

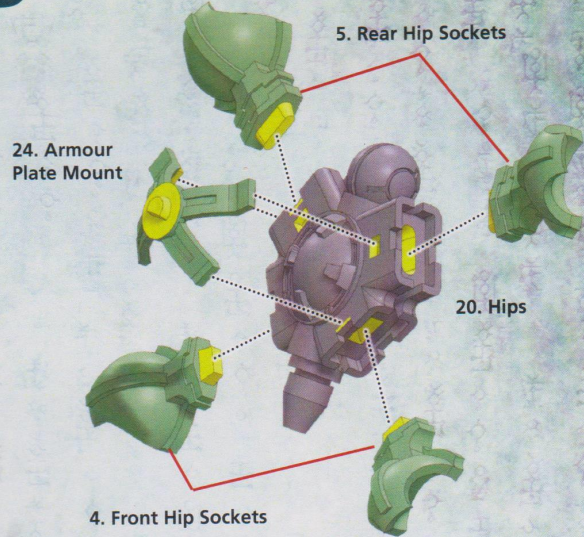

5. Rear Hip Sockets

24. Armour Plate Mount

20. Hips

4. Front Hip Sockets

9

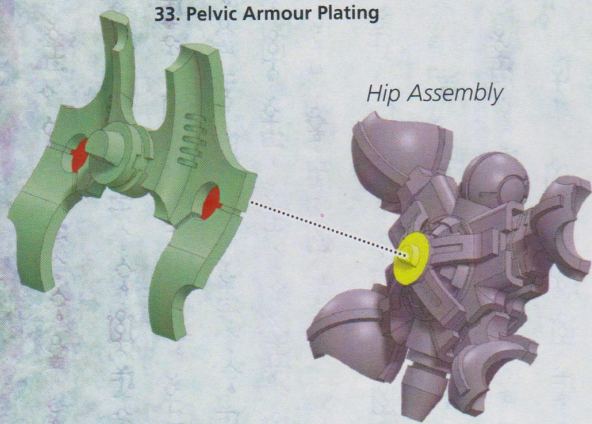

33. Pelvic Armour Plating

Hip Assembly

10

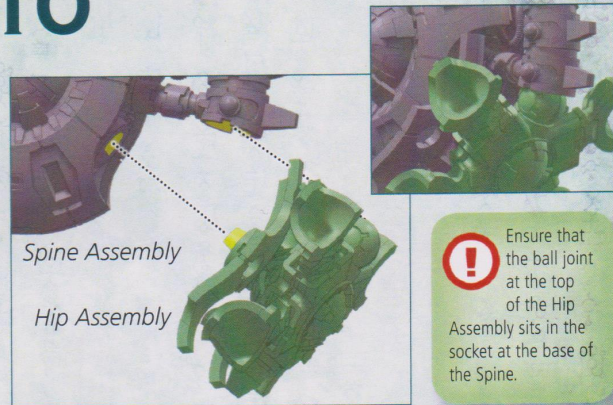

Spine Assembly

Hip Assembly

! Ensure that the ball joint at the top of the Hip Assembly sits in the socket at the base of the Spine.

11

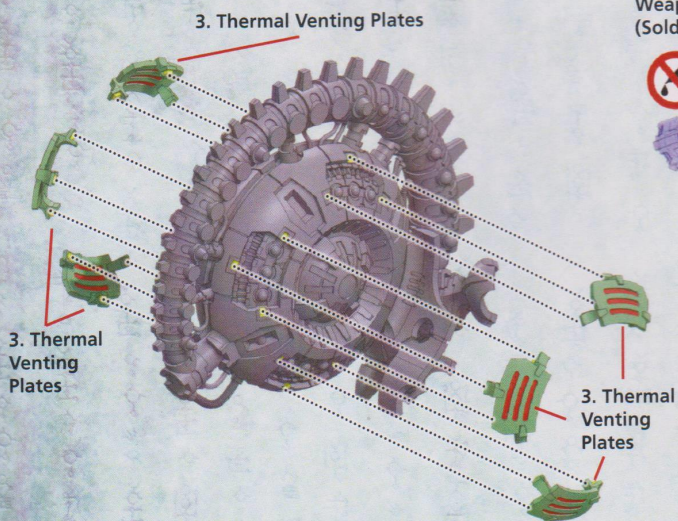

3. Thermal Venting Plates

3. Thermal Venting Plates

3. Thermal Venting Plates

12

Weapon Mount (Sold Separately)

! Use the Weapon Mounts for whichever weapon system you would like to use (sold separately) to determine the correct position of the Weapon Support Arms.

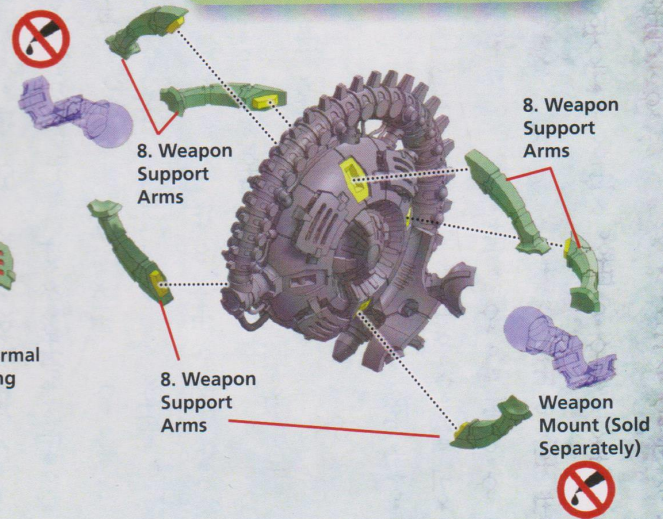

8. Weapon Support Arms

8. Weapon Support Arms

8. Weapon Support Arms

Weapon Mount (Sold Separately)



13



With all Weapon Support Arms securely in place, the Weapon Mount should be able to pop in and out of the socket.

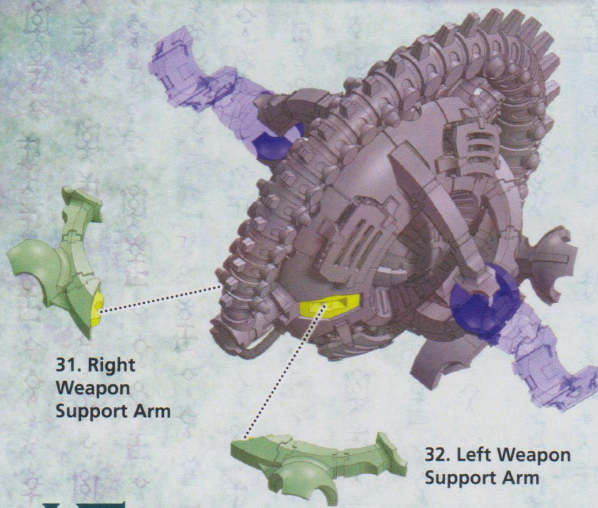

31. Right Weapon Support Arm

32. Left Weapon Support Arm

14

34. Right Spinal Plating

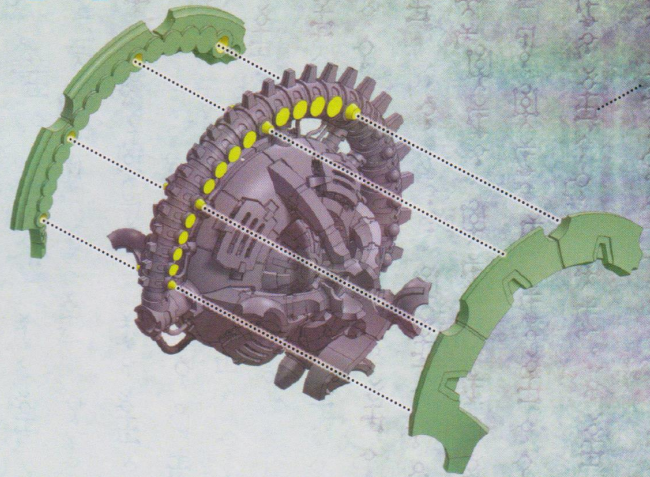

35. Left Spinal Plating

15

9. Central Shoulder Plate

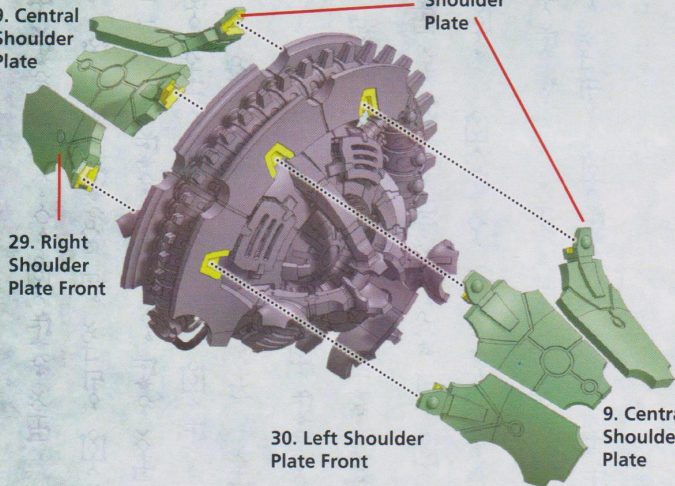

10. Rear Shoulder Plate

29. Right Shoulder Plate Front

30. Left Shoulder Plate Front

9. Central Shoulder Plate

16

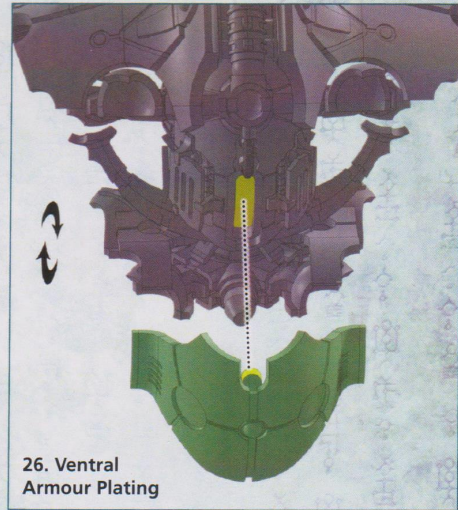

26. Ventral Armour Plating

17

1. Right Lower Arm



2. Left Lower Arm

7. Blade



Repeat assembly stages 17 and 18 twice for both Fore Arm blades. Part 7. Blade should be able to move up and down.

18

Fore Arm Blade Assembly

13. Arm Upper

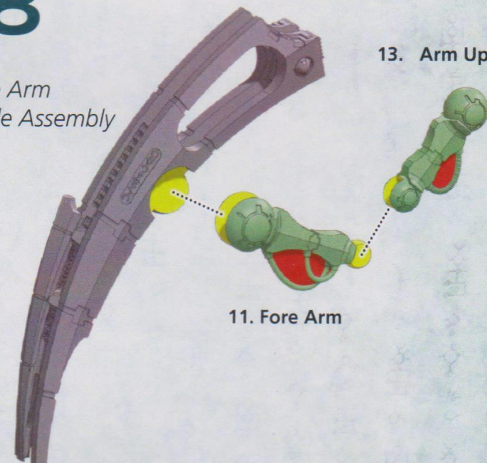

11. Fore Arm

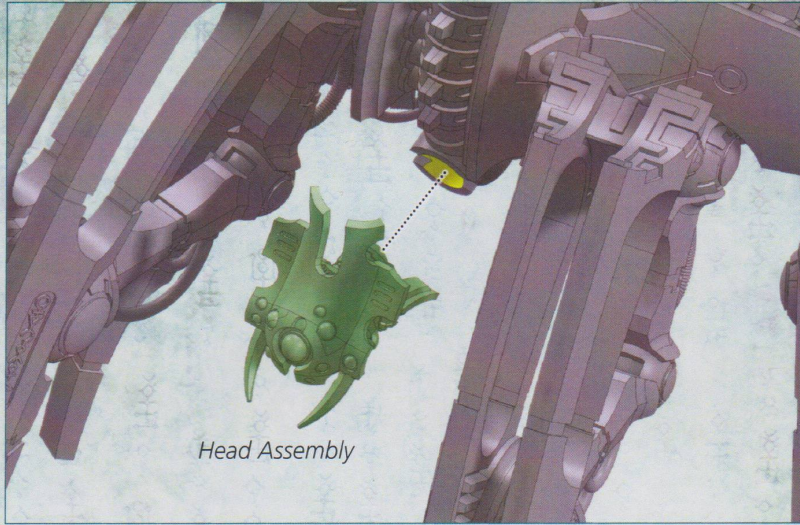

 A number of different weapon options are available (sold separately) to mount on your Necron Seraptak Heavy Construct. For more details, visit forgeworld.co.uk.

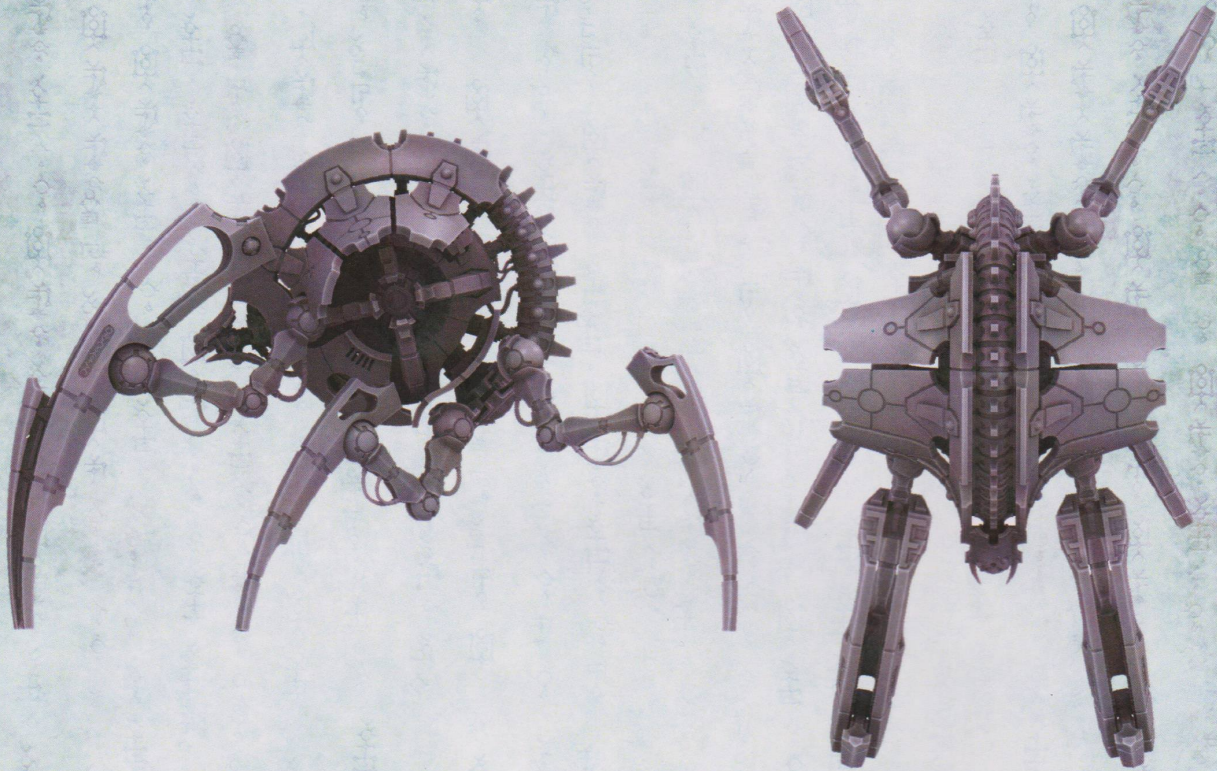

© Copyright Games Workshop Limited 2018. All rights reserved.

www.forgeworld.co.uk

**GAMES
WORKSHOP**
games-workshop.com



Forge World®