

WARHAMMER 40,000 TAU EMPIRE

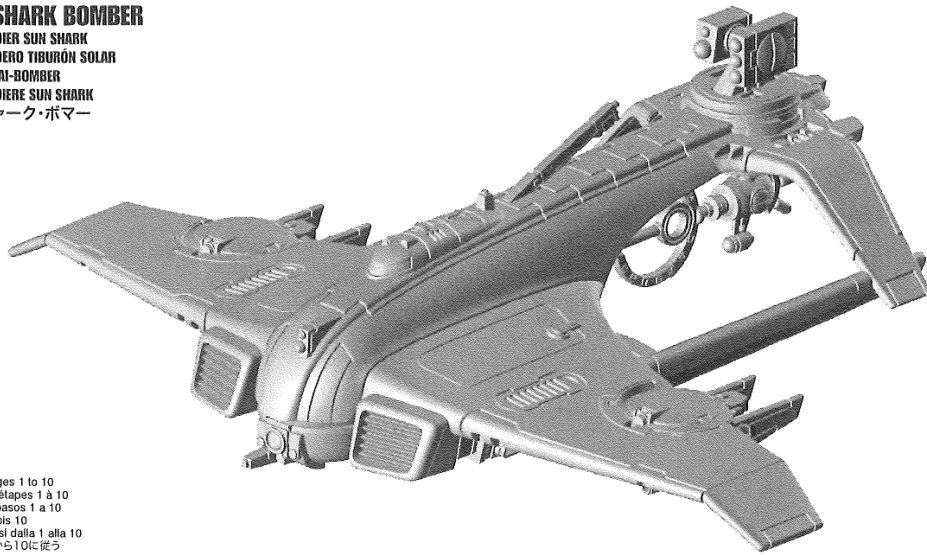

SUN SHARK BOMBER

BOMBARDIER SUN SHARK
BOMBARDERO TIBURÓN SOLAR
SONNENHAJ-BOMBER
BOMBARDIERE SUN SHARK
サンシャーク・ボマー



Follow stages 1 to 10
Suivre les étapes 1 à 10
Sigue los pasos 1 a 10
Schritte 1 bis 10
Segui le fasi dalla 1 alla 10
ステップ1から10に従う

RAZORSHARK STRIKE FIGHTER

CHASSEUR RAZORSHARK
CAZA TIBURÓN LANZA
KLINGENHAJ-JAGDBOMBER
CACCIA D'ASSALTO RAZORSHARK
レイザーシャーク・ストライクファイター

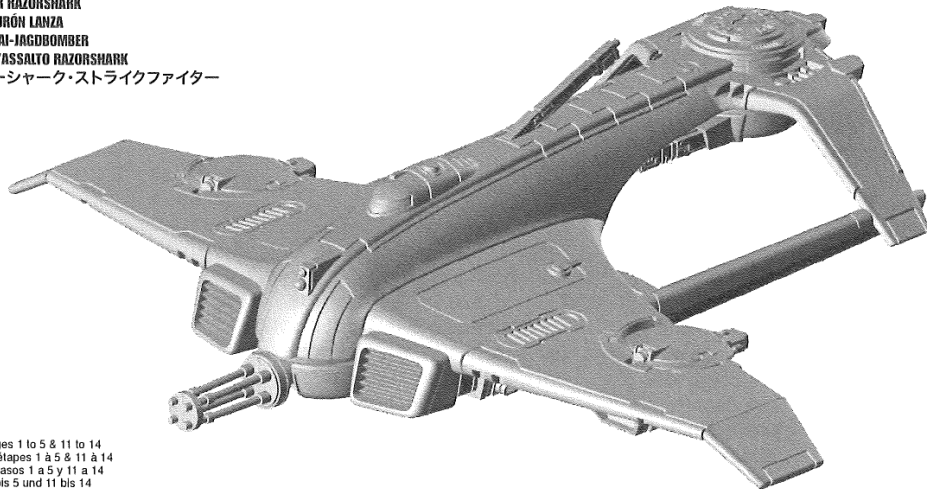

Follow stages 1 to 5 & 11 to 14
Suivre les étapes 1 à 5 & 11 à 14
Sigue los pasos 1 a 5 y 11 a 14
Schritte 1 bis 5 und 11 bis 14
Segui le fasi da 1 a 5 e da 11 a 14
ステップ1から5と11から14に従う

EXPLANATION OF SYMBOLS

EXPLICATION DES SYMBOLES • EXPLICACIÓN DE SÍMBOLOS
ERLÄUTERUNG DER SYMBOLE • LEGENDA DEI SIMBOLI • アイコンの説明



SPECIAL INSTRUCTION - PLEASE READ
INSTRUCTIONS SPECIALES - LIRE ATTENTIVEMENT
INSTRUCCIÓN ESPECIAL: POR FAVOR, LÉELA
BESONDERE ANWEISUNG - BITTE LESEN
ISTRUZIONI SPECIALI - LEGGI ATTENTAMENTE
特記事項 - 必ず読んでください



FINISHED ASSEMBLY
ASSEMBLAGE TERMINÉ
MONTAJE FINALIZADO
FERTIGER ZUSAMMENBAU
ASSEMBLAGGIO COMPLETO
完成例



ALTERNATE ANGLE
VUE ALTERNATIVE
ÁNGULO INVERSO
ALTERNATIVE ANSICHT
VISUALE ALTERNATIVA
別の角度から見た図



DO NOT GLUE THE COMPONENTS
NE PAS COLLER LES ÉLÉMENTS
NO PEGAR LOS COMPONENTES
BITTE DIE TEILE NICHT KLEBEN
NON INCOLLARE I COMPONENTI
パーツを接着しないこと



CHOICE OF PARTS
CHOIX D'ÉLÉMENTS
MODELOS DE COMPONENTES
AUSWAHL AN TEILEN
SCELTA DI COMPONENTI
パーツの選択



CLOSE-UP VIEW
VUE RAPPROCHÉE
PRIMER PLANO
NAHANSICHT
INGRANDIMENTO
拡大図



1 MISSILE ASSEMBLY • ASSEMBLAGE DES MISSILES • MONTAJE DE LOS MISILES
 ZUSAMMENBAU DER RAKETEN • ASSEMBLAGGIO DEI MISSILI • ミサイルの組み立て

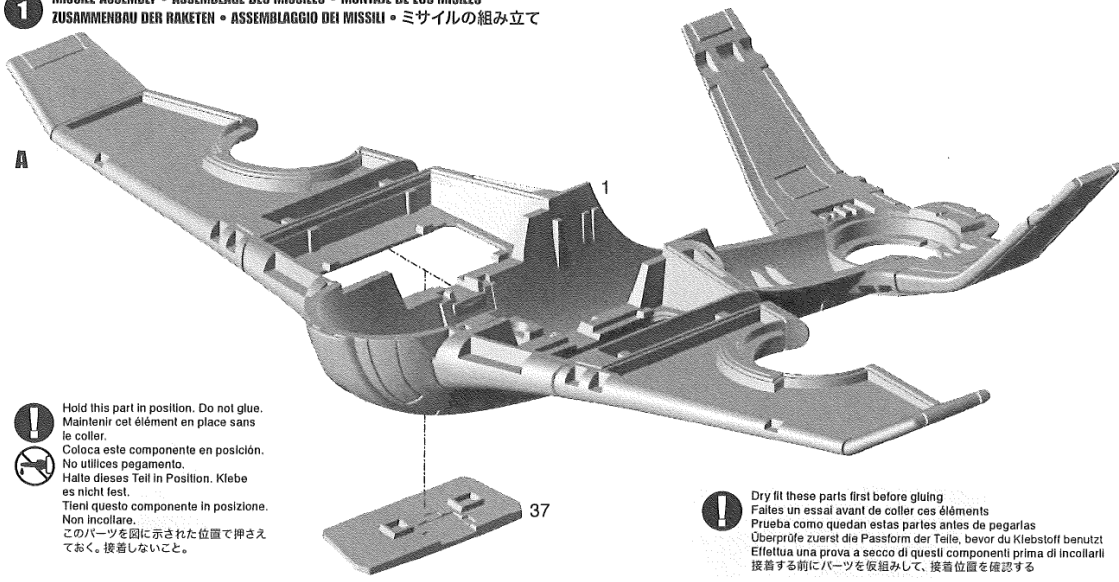

A

! Hold this part in position. Do not glue.
 Maintenir cet élément en place sans le coller.
! Coloca este componente en posición. No utilices pegamento.
 Halte dieses Teil in Position. Klebe es nicht fest.
 Tieni questo componente in posizione. Non incollare.
 このパーツを図に示された位置で押さえておく。接着しないこと。

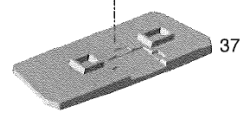

! Dry fit these parts first before gluing
 Faites un essai avant de coller ces éléments
 Pruebe como quedan estas partes antes de pegarlas
 Überprüfe zuerst die Passform der Teile, bevor du Klebstoff benutzt
 Effettua una prova a secco di questi componenti prima di incollarli
 接着する前にパーツを仮組みして、接着位置を確認する

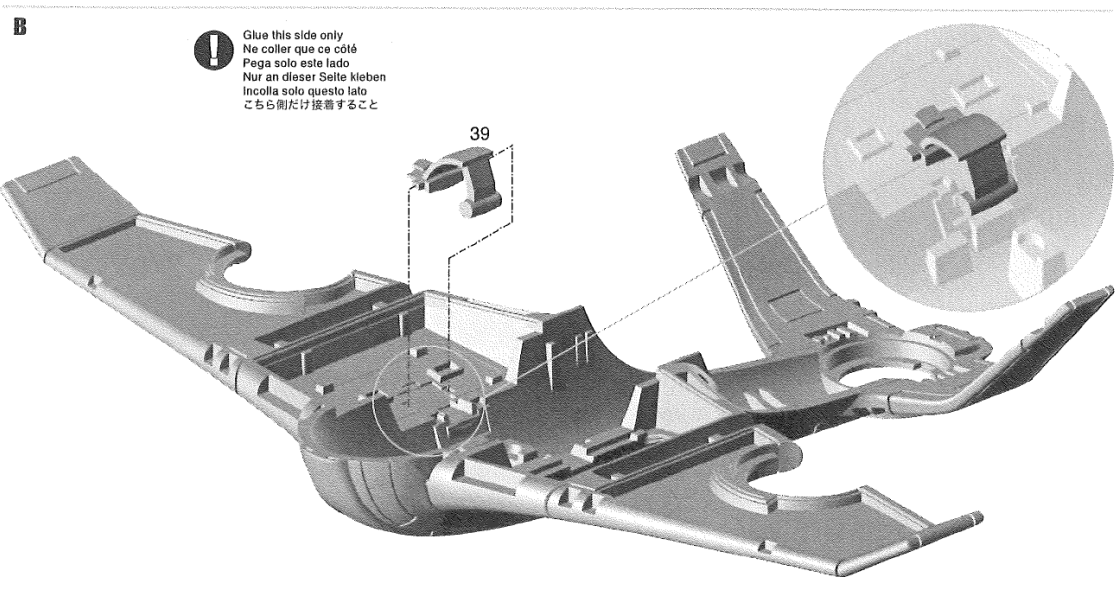

B

! Glue this side only
 Ne coller que ce côté
 Pega solo este lado
 Nur an dieser Seite kleben
 Incolla solo questo lato
 こちら側だけ接着すること

39

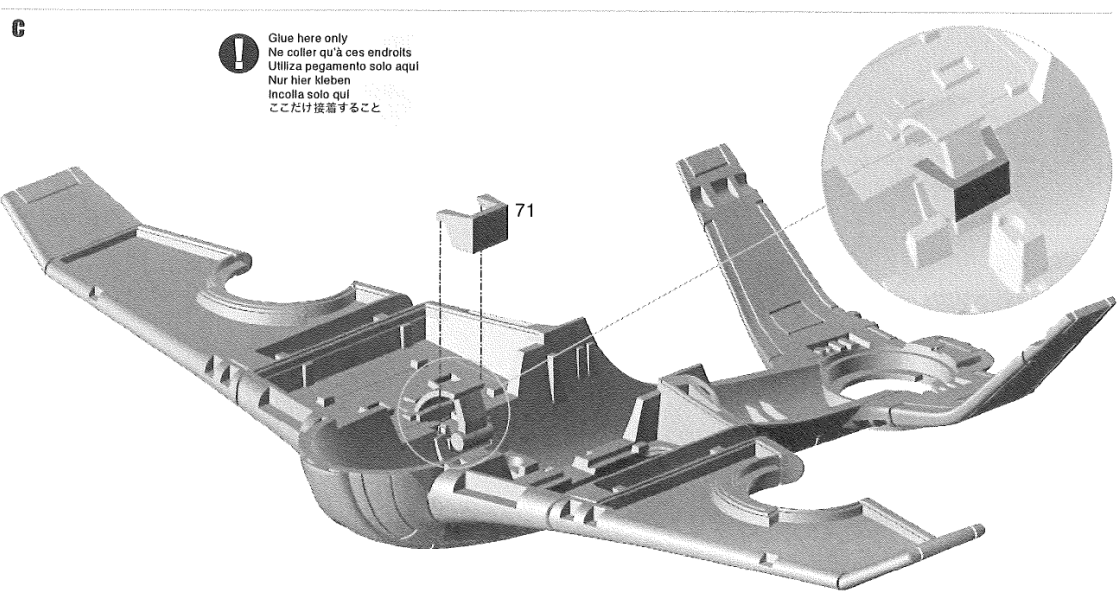
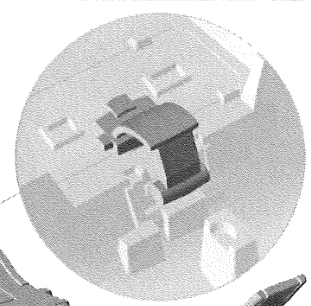

C

! Glue here only
 Ne coller qu'à ces endroits
 Utiliza pegamento solo aqui
 Nur hier kleben
 Incolla solo qui
 ここだけ接着すること

71

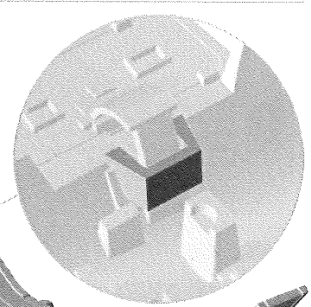

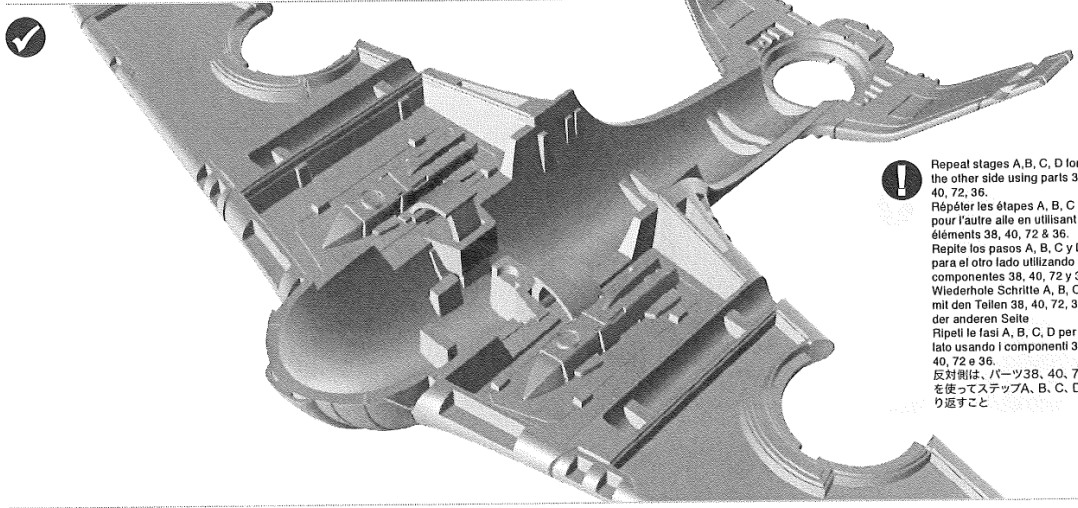
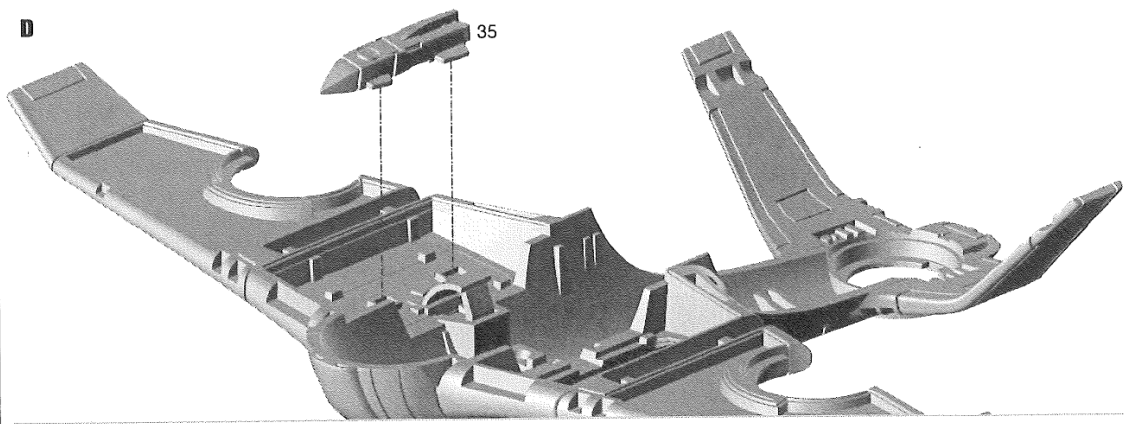

! Repeat stages A, B, C, D for the other side using parts 38, 40, 72, 36.
 Répéter les étapes A, B, C & D pour l'autre aile en utilisant les éléments 38, 40, 72 & 36.
 Repite los pasos A, B, C y D para el otro lado utilizando los componentes 38, 40, 72 y 36.
 Wiederhole Schritte A, B, C, D mit den Teilen 38, 40, 72, 36 auf der anderen Seite.
 Ripeti le fasi A, B, C, D per l'altro lato usando i componenti 38, 40, 72 e 36.
 反対側は、パーツ38、40、72、36を使ってステップA、B、C、Dを繰り返すこと

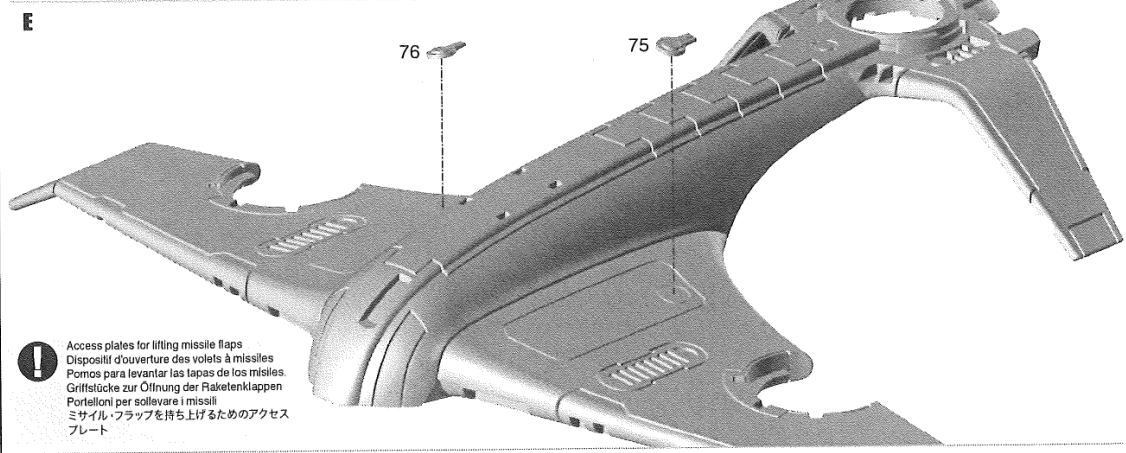

! Access plates for lifting missile flaps
 Dispositif d'ouverture des volets à missiles
 Pomos para levantar las tapas de los misiles
 Griffstücke zur Öffnung der Raketenklappen
 Portelloni per sollevare i missili
 ミサイル・フラップを持ち上げるためのアクセスプレート

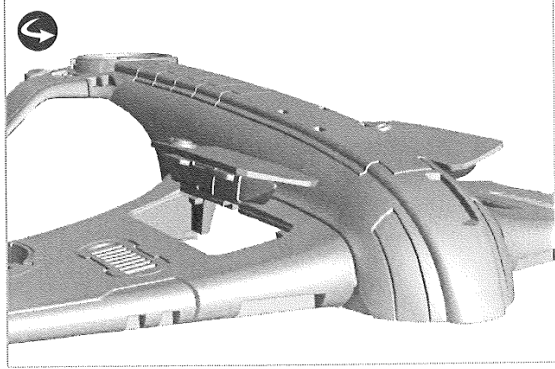
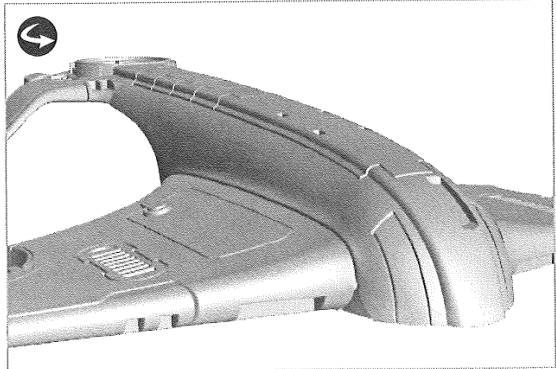

2 ENGINES ASSEMBLY • ASSEMBLAGE DES RÉACTEURS • MONTAJE DE LOS MOTORES
ZUSAMMENBAU DER TRIEBWERKE • ASSEMBLAGGIO DEI MOTORI • エンジンの組み立て

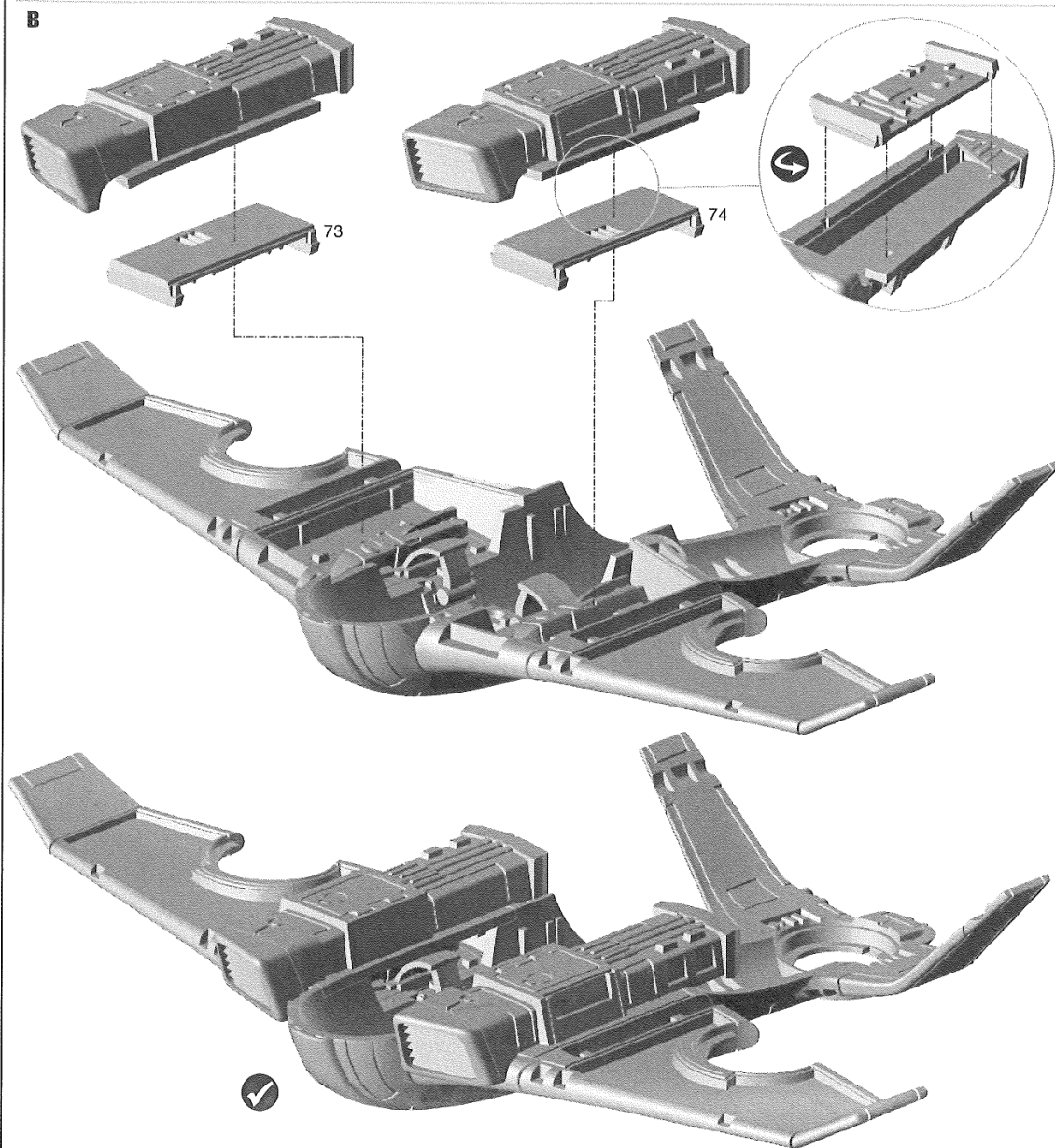
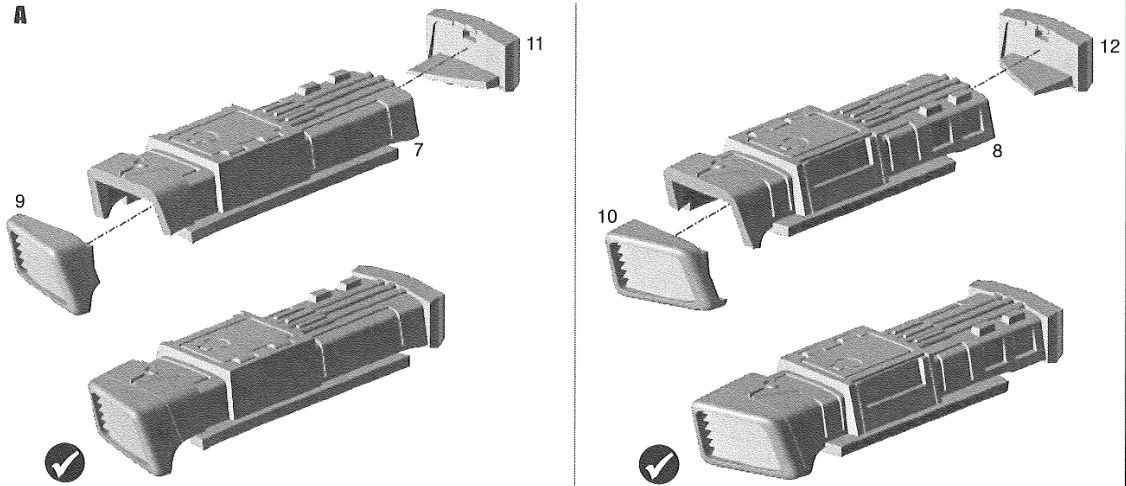

3 HULL ASSEMBLY • ASSEMBLAGE DU FUSELAGE
MONTAJE DEL CASCO • ZUSAMMENBAU DES RUMPFS
ASSEMBLAGGIO DELLO SCAFO • 機体の組み立て

A



! Assemble in this order 70 - 69 - 4
Assembler dans cet ordre : 70 - 69 - 4
Móntalo en este orden 70 - 69 - 4
Baue dies in der Reihenfolge 70 - 69 - 4 zusammen
Assembla in questo ordine: 70 - 69 - 4
70、69、4の順に組み立てること

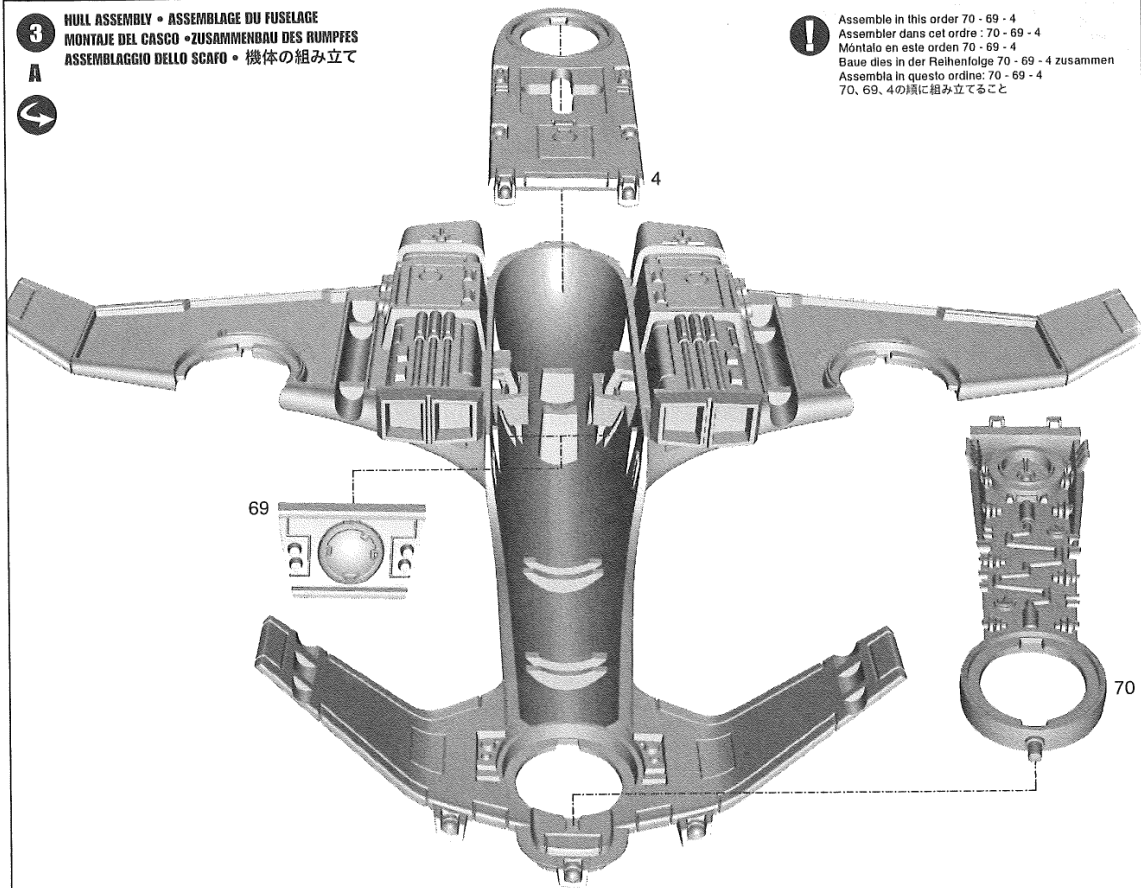

B

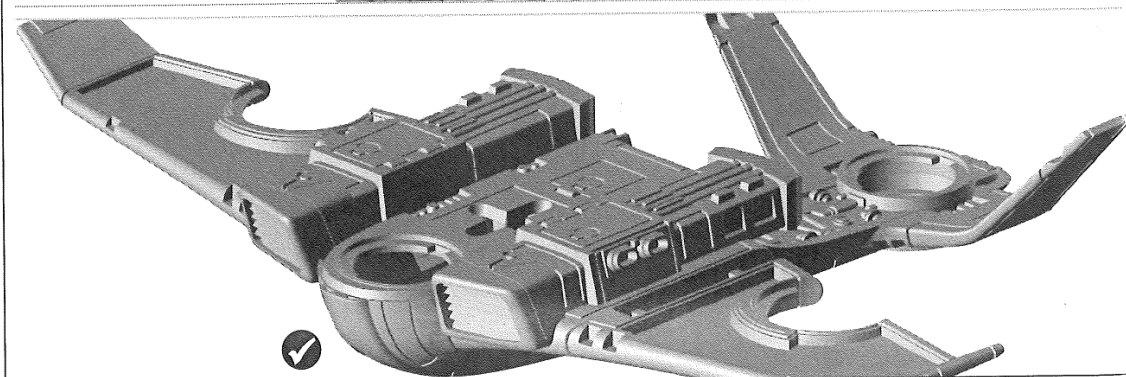
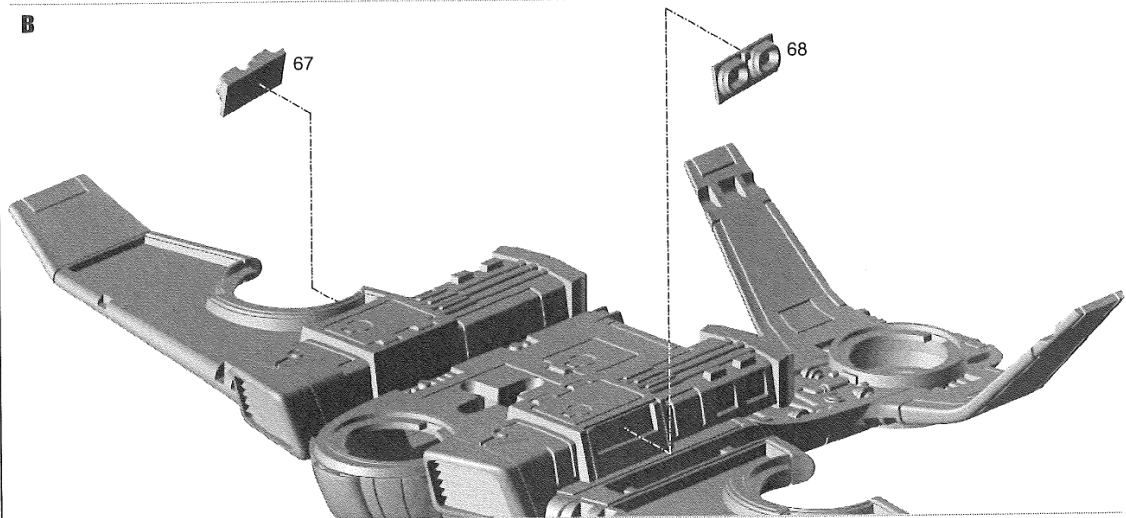

4 HULL ASSEMBLY contd.
ASSEMBLAGE DU FUSELAGE suite
MONTAJE DEL CASCO (Cont.)
A ZUSAMMENBAU DES RUMPFS, Forts.
ASSEMBLAGGIO DELLO SCAFO (segue)
機体の組み立て(続き)

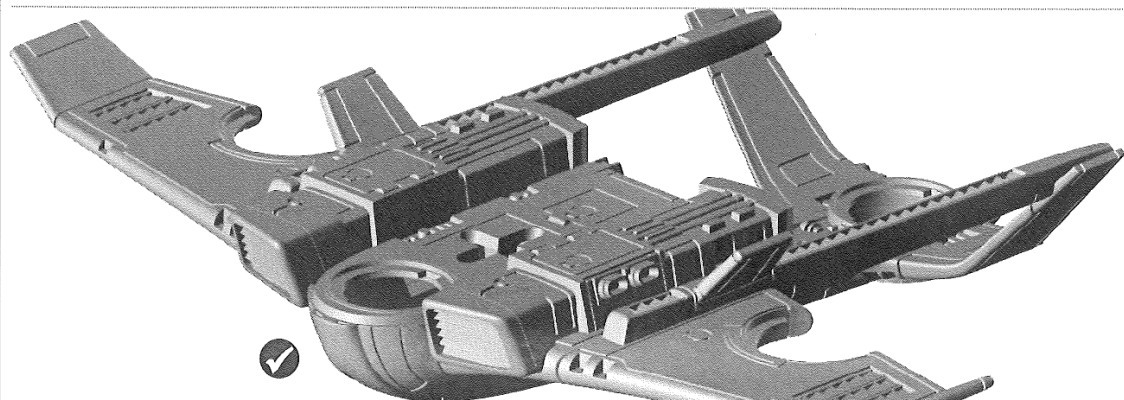
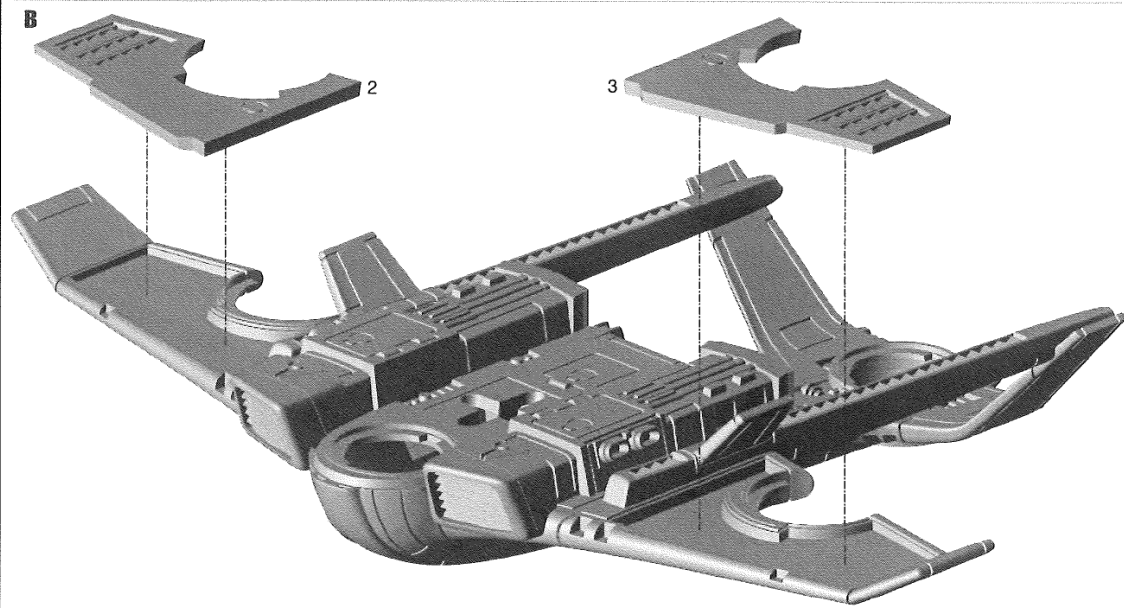
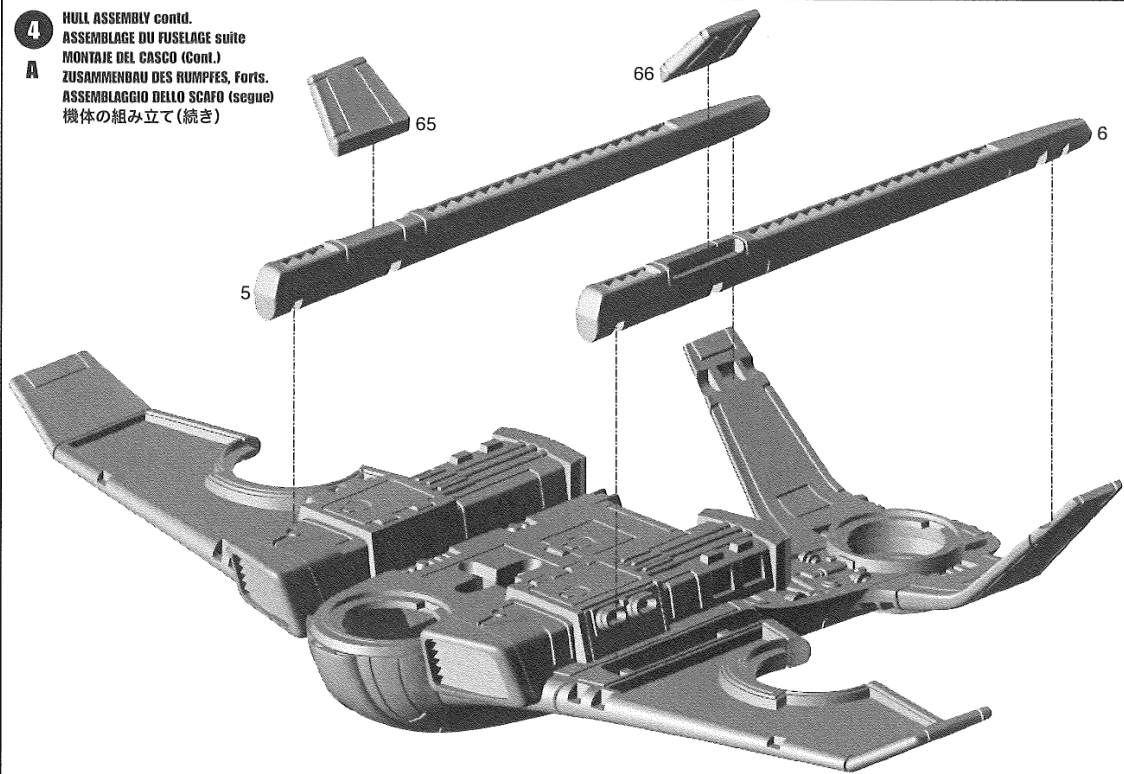

5 HULL ASSEMBLY contd.
 ASSEMBLAGE DU FUSELAGE suite
 MONTAJE DEL CASCO (Cont.)
 ZUSAMMENBAU DES RUMPFS, Forts.
 ASSEMBLAGGIO DELLO SCAFO (segue)
 機体の組み立て(続き)

! Antenna can be attached anywhere
 L'antenne peut être placée où bon vous semble
 Puedes pegar las antenas donde quieras
 Antenne kann beliebig angebracht werden
 L'antenna può essere incollata ovunque
 アンテナは好きな場所に取り付けられる

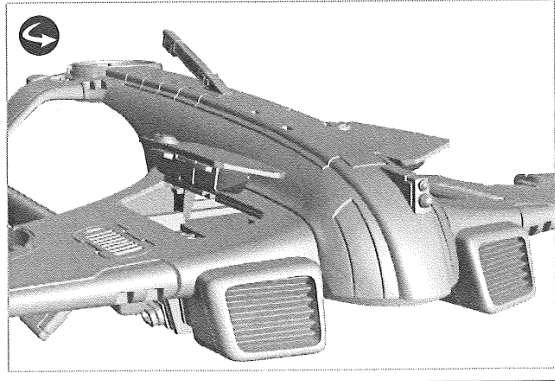
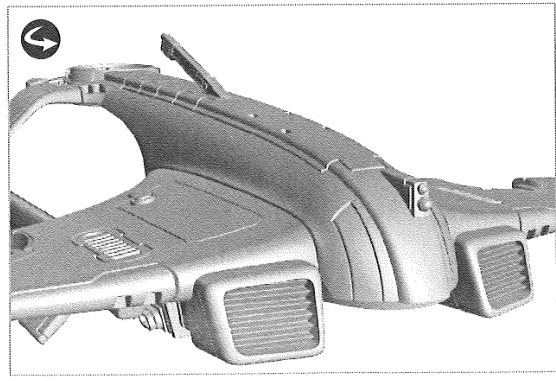
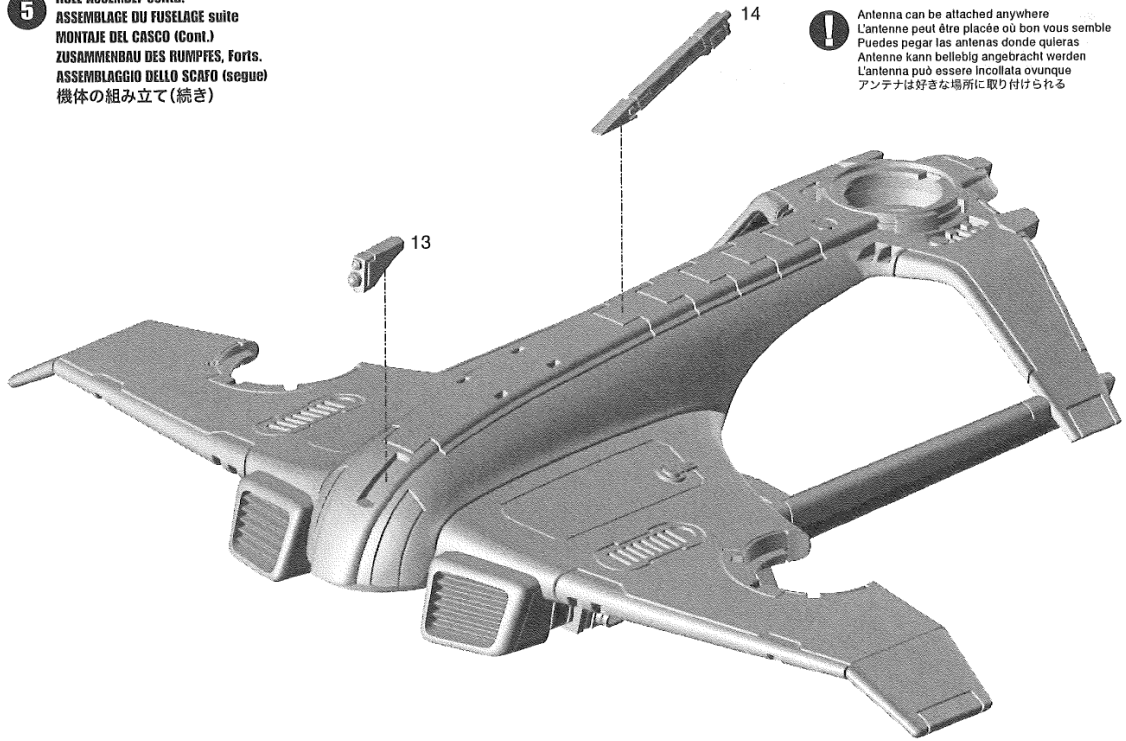

CHOOSE THE FLYER YOU WANT TO BUILD • CHOISISSEZ LA VARIANTE QUE VOUS DÉSIREZ ASSEMBLER • ELIGE QUÉ VOLADOR QUIERES MONTAR
ENTSCHEIDE, WELCHEN FLIEGER DU Bauen MÖCHTEST • SCEGLI IL VELIVOLO CHE VUOI ASSEMBLARE • 組み立てたいフライヤーを選択

SUN SHARK BOMBER

BOMBARDIER SUN SHARK
BOMBARDERO TIBURÓN SOLAR
SONNENHAI-BOMBER
BOMBARDIERE SUN SHARK
サンシャーク・ボマー

Follow stages 6 to 10
Suivre les étapes 6 à 10
Sigue los pasos 6 a 10
Schritte 6 bis 10
Segui le fasi dalla 6 alla 10
ステップ6から10に従う

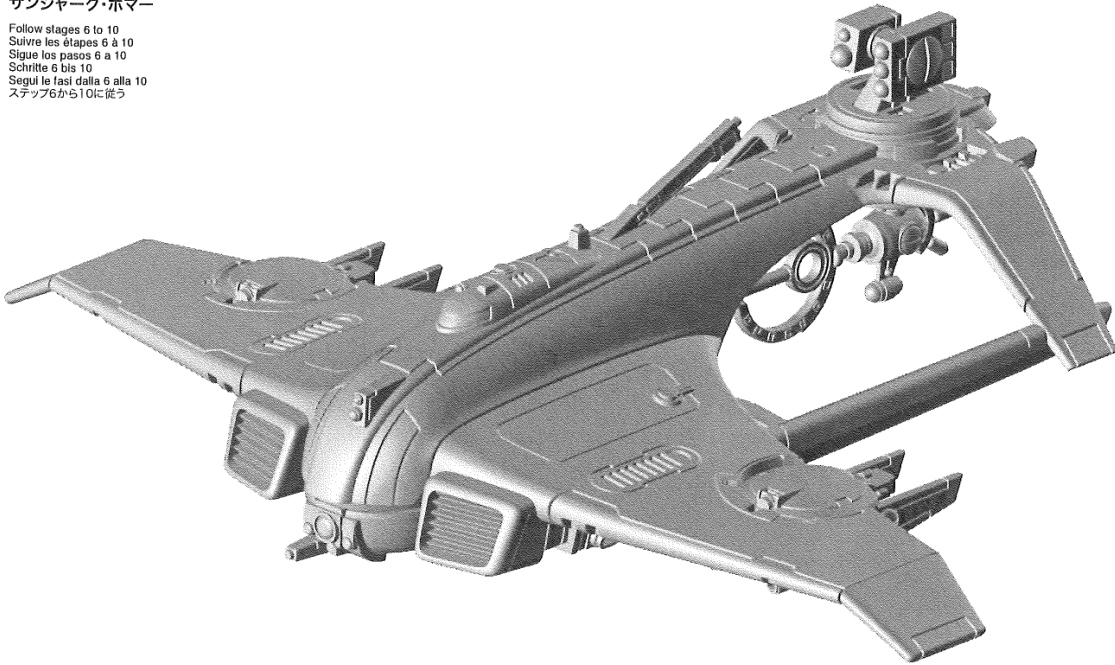

RAZORSHARK STRIKE FIGHTER

CHASSEUR RAZORSHARK
CAZA TIBURÓN LANZA
KLINGENHAI-JAGDBOMBER
CACCHIA D'ASSALTO RAZORSHARK
レイザーシャーク・ストライクファイター

Follow stages 11 to 14
Suivre les étapes 11 à 14
Sigue los pasos 11 a 14
Schritte 11 bis 14
Segui le fasi dalla 11 alla 14
ステップ11から14に従う

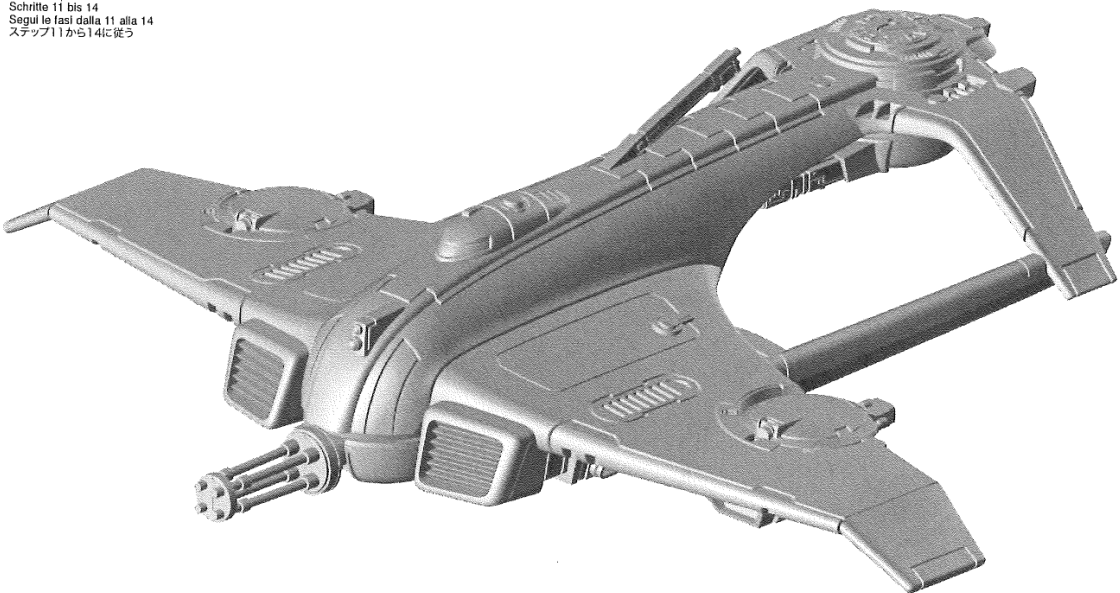

6 DRONES • DRONES • DRONES • DROHNEN • DRONI • ドローン

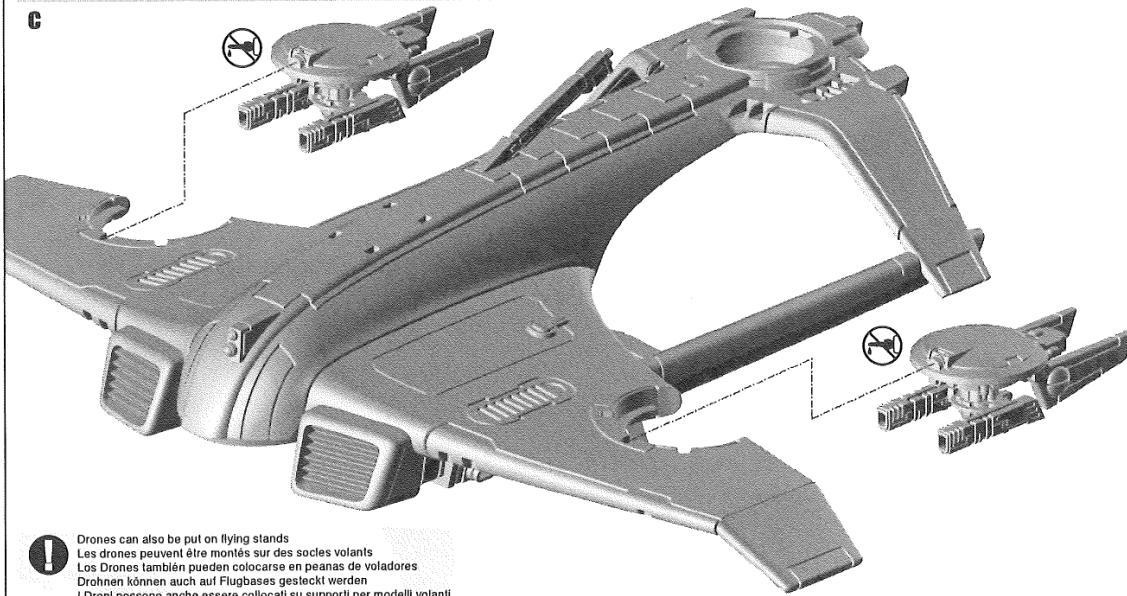
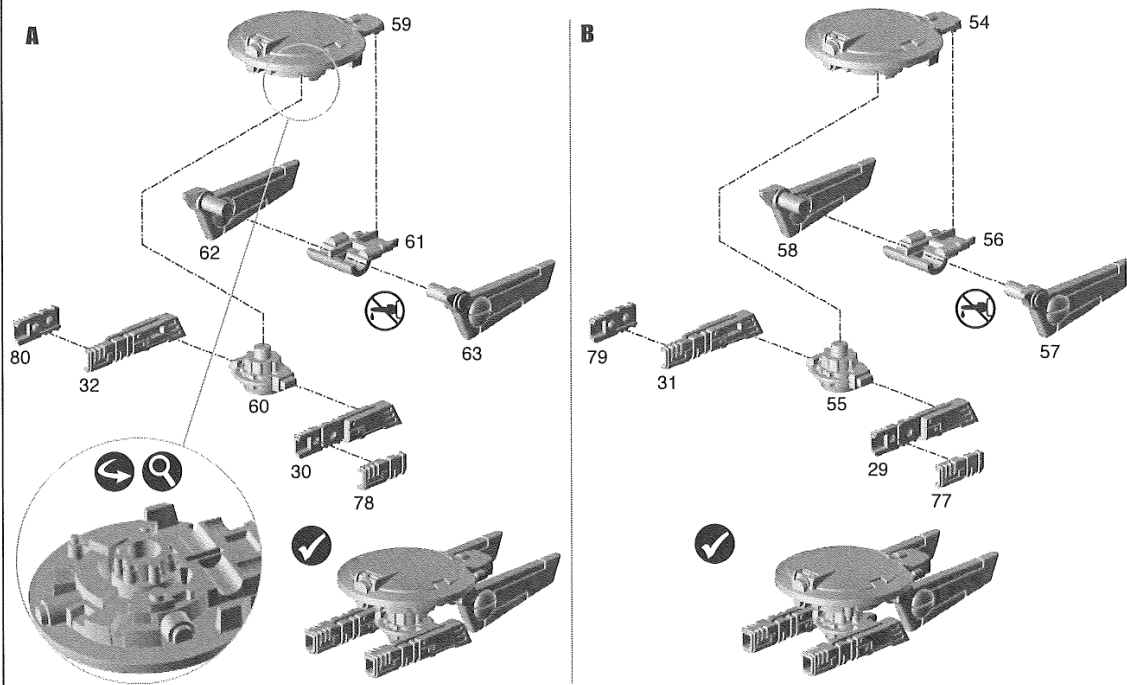

! Drones can also be put on flying stands
 Les drones peuvent être montés sur des socles volants
 Los Drones también pueden colocarse en peanas de voladores
 Drohnen können auch auf Flugbases gesteckt werden
 I Droni possono anche essere collocati su supporti per modelli volanti
 ドローンはフライングスタンドにも取り付け可能

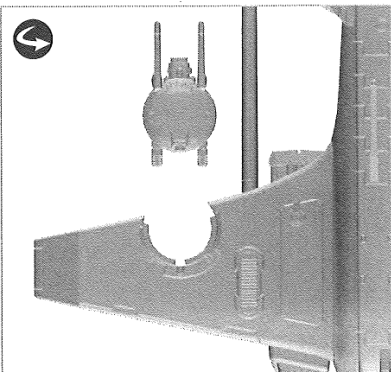
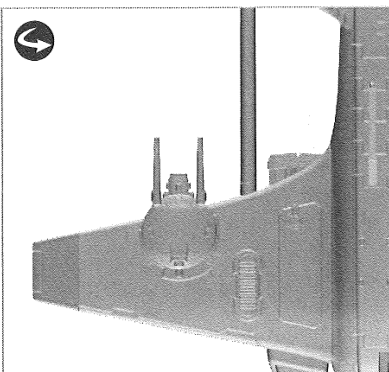
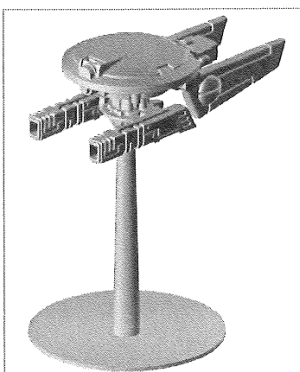

7 FRONT WEAPONS • ARMEMENT AVANT • ARMAS FRONTALES • BUGWAFFEN • ARMI FRONTALI • 武器 (前方)

A

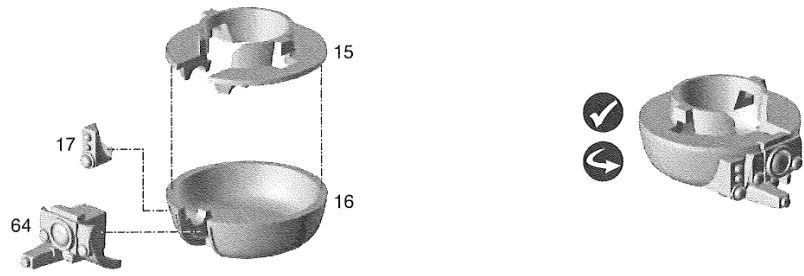

B

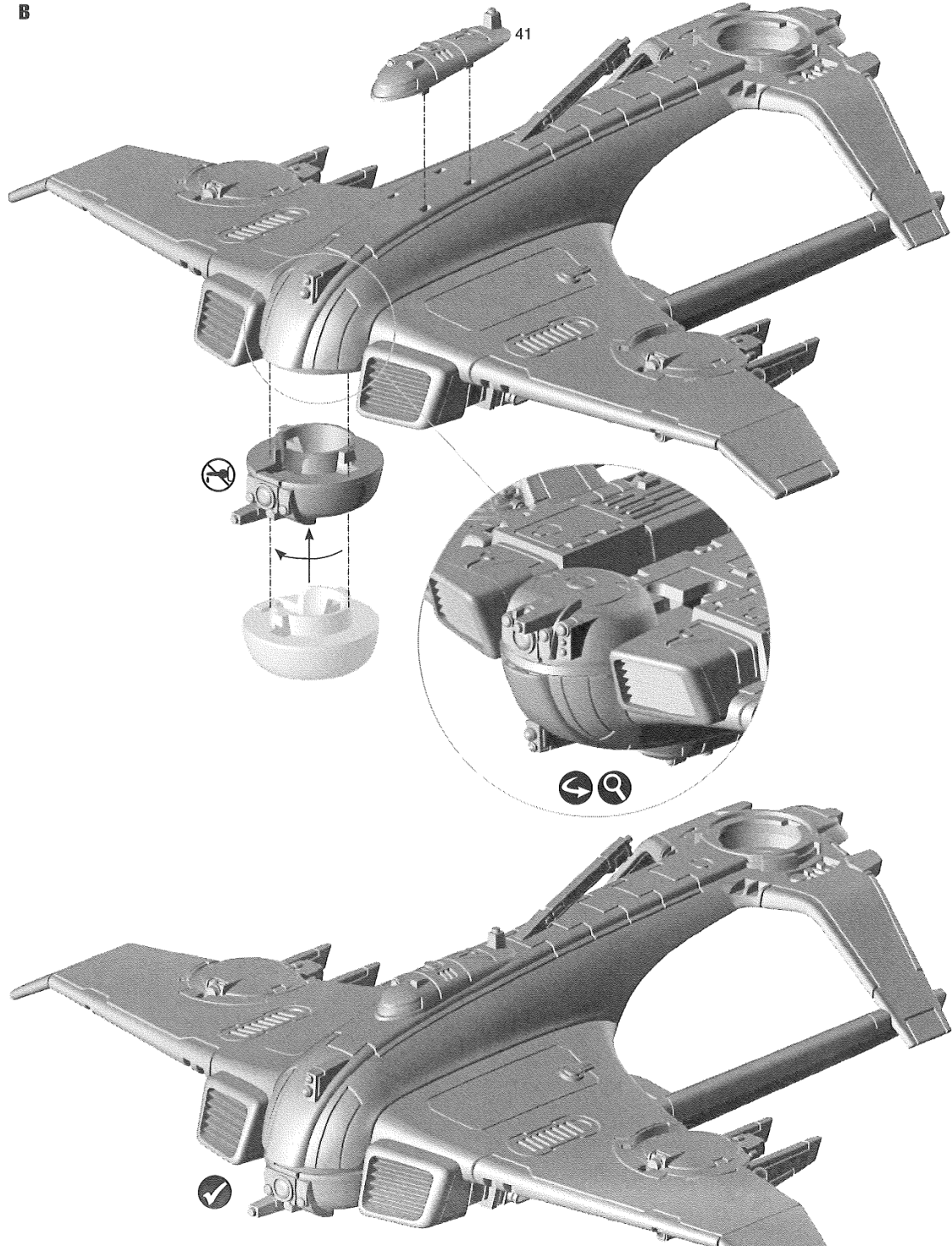

8 REAR WEAPONS • ARMEMENT ARRIÈRE • ARMAS POSTERIORES • HECKWAFFEN • ARMI POSTERIORI • 武器 (後方)

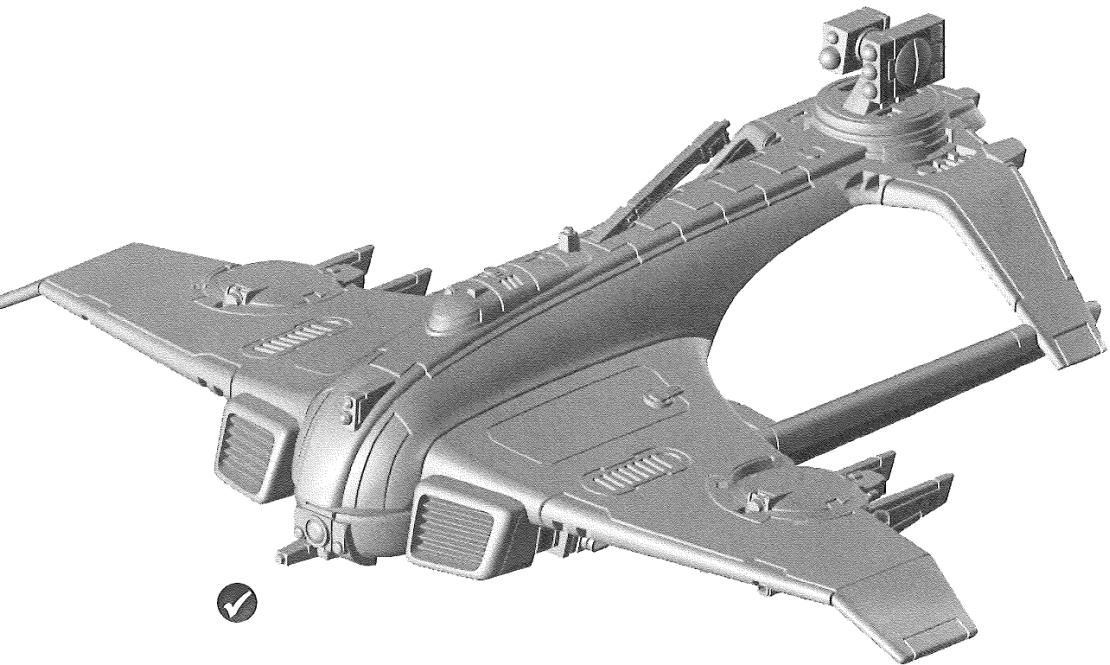
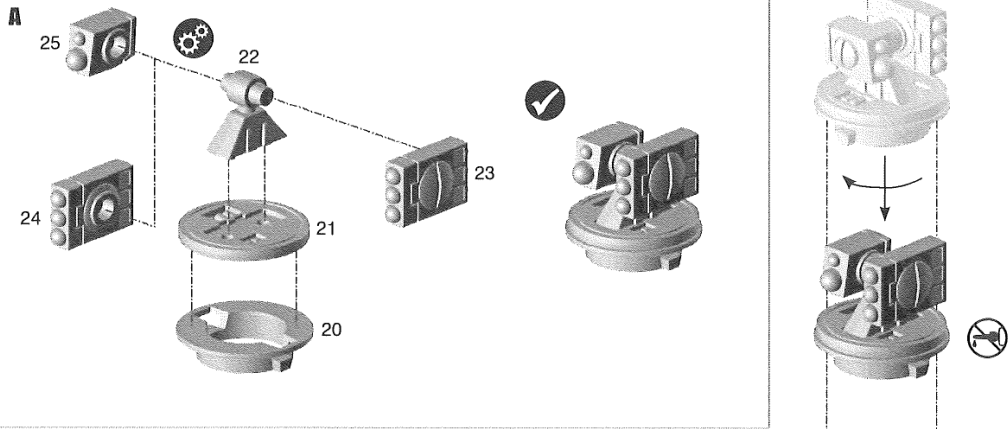

9 MAIN WEAPON • ARMEMENT ARRIÈRE • ARMA PRINCIPAL • HAUPTWAFFE • ARMA PRINCIPALE • 主要武器

! Parts 52 & 53 can rotate. Do not glue.
 Les éléments 52 & 53 peuvent pivoter. Ne pas coller.
 Los componentes 52 y 53 pueden rotarse. No los pegues.
 Teile 52 & 53 können sich drehen. Nicht festkleben.
 I componenti 52 e 53 possono ruotare. Non incollare.
 パーツ52番と53番は回転させられる。接着しないこと。

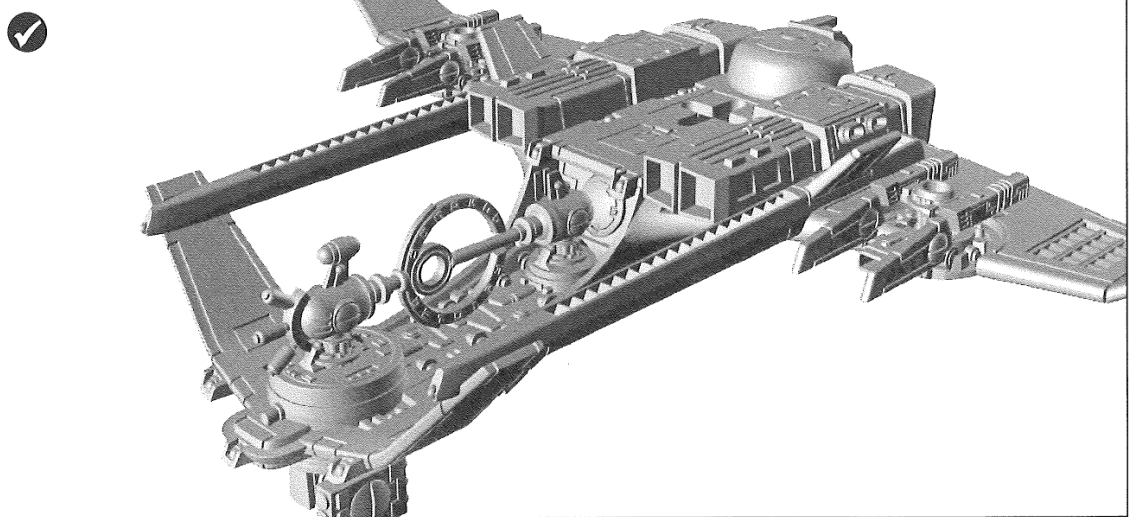
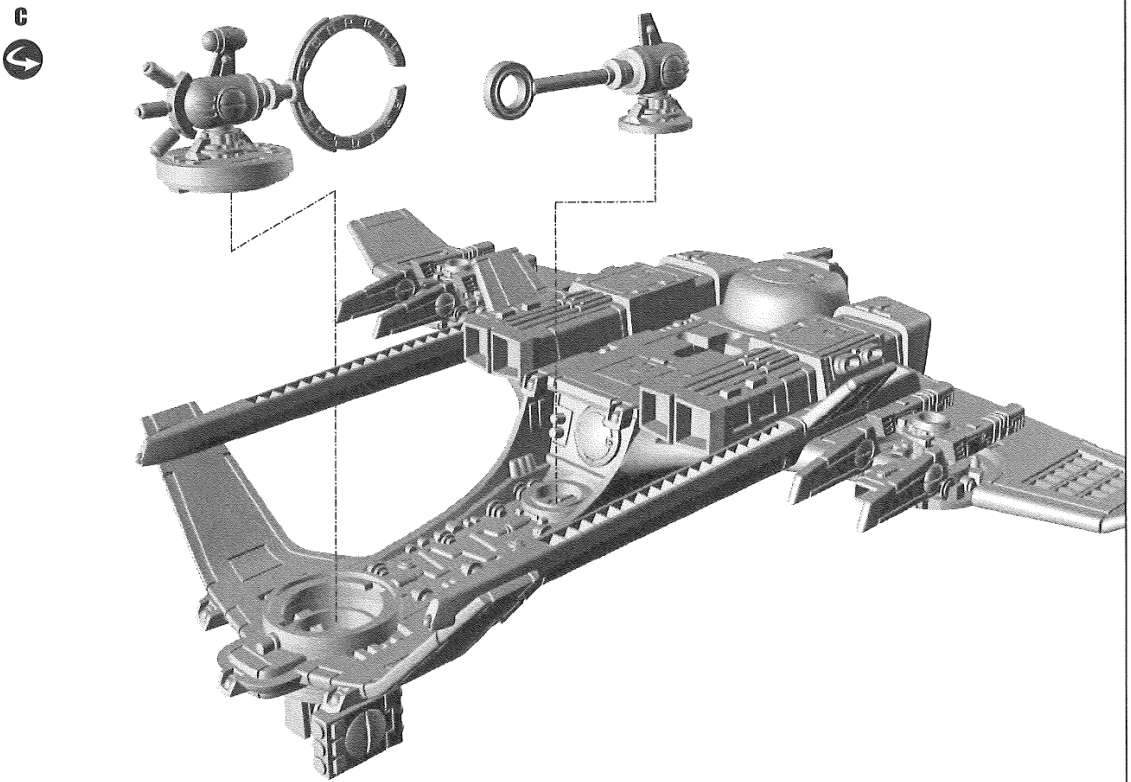
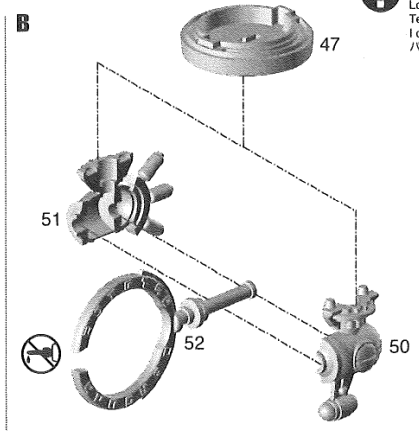
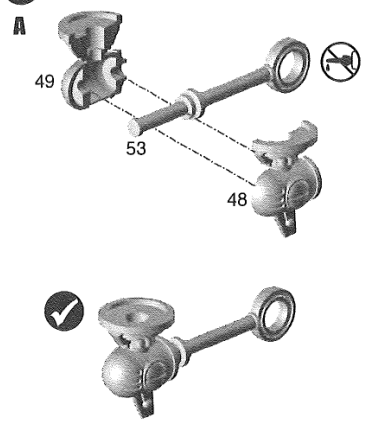

10 FINAL ASSEMBLY • ASSEMBLAGE FINAL • MONTAJE FINAL • ABSCHLIESSENDE ZUSAMMENBAU • ASSEMBLAGGIO FINALE • 最終組み立て

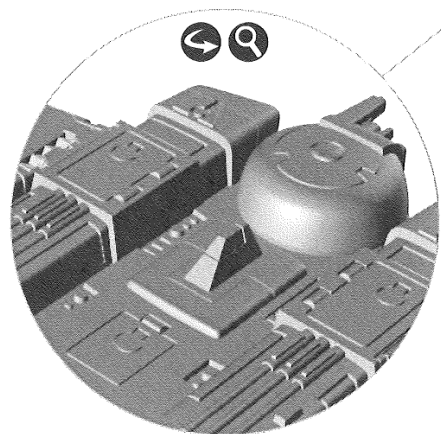
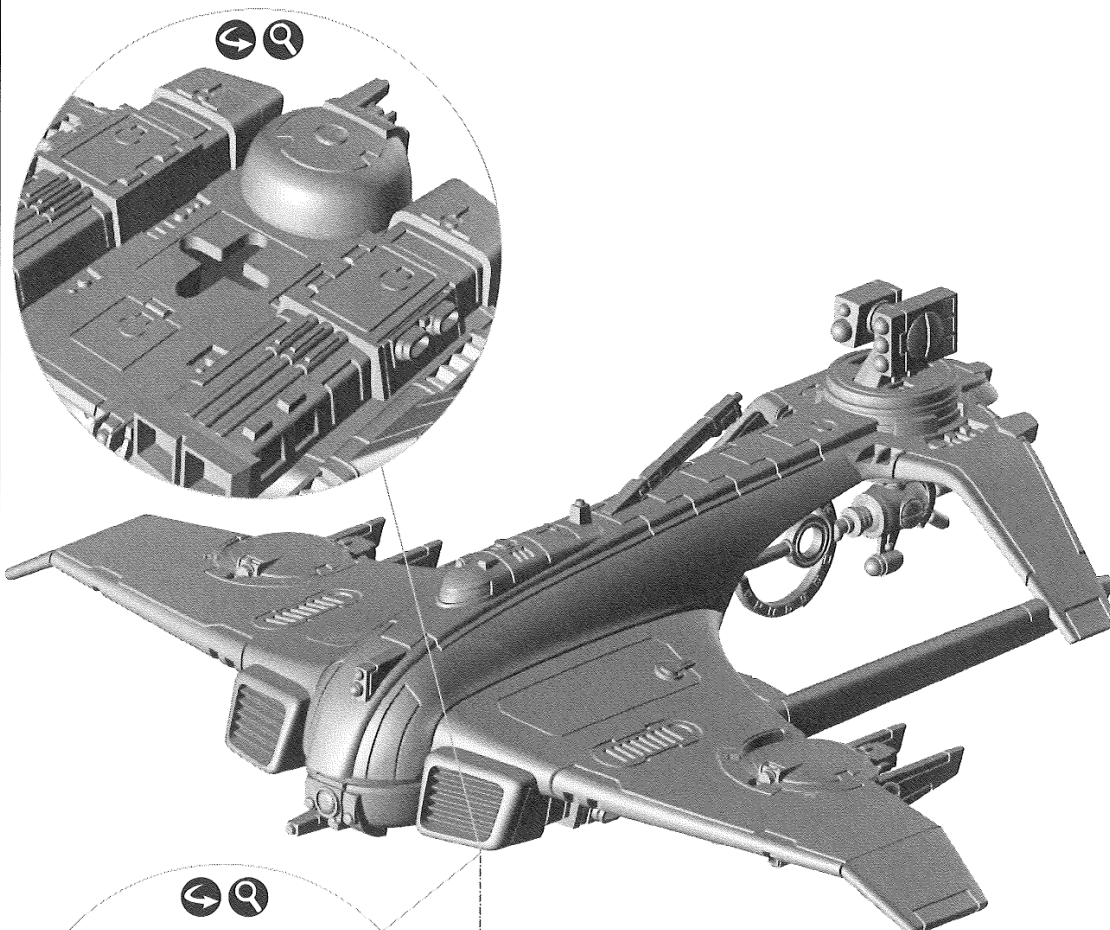

! If you do not use the flying stand attach the cover hatch instead
Si vous n'utilisez pas le socle volant, placez le cache
Si no utilizas peanas de voladores pega la tapa de la escollilla
Wenn du nicht das Flugbase benutzt, bringe stattdessen den Lukendeckel an
Se non utilizzi il supporto per modelli volanti, incolla il portellone
フライングスタンドを使用しない場合は、代わりにカバーハッチを取り付ける

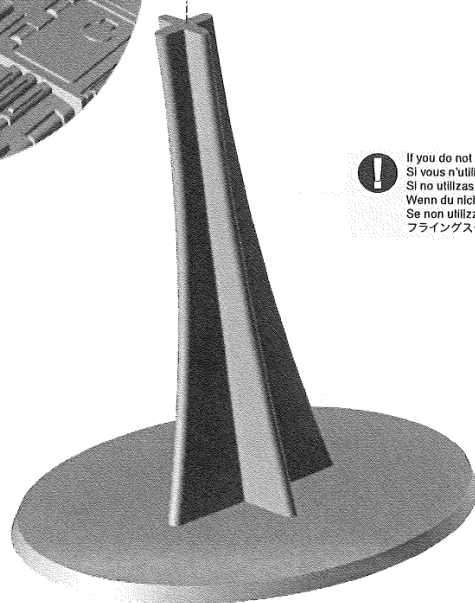

SUN SHARK BOMBER

BOMBARDIER SUN SHARK
BOMBARDERO TIBURÓN SOLAR
SONNENHAI-BOMBER
BOMBARDIERE SUN SHARK
サンシャーク・ボマー



11 DRONES • DRONES • DRONES • DRONEN • DRONI • ドローン

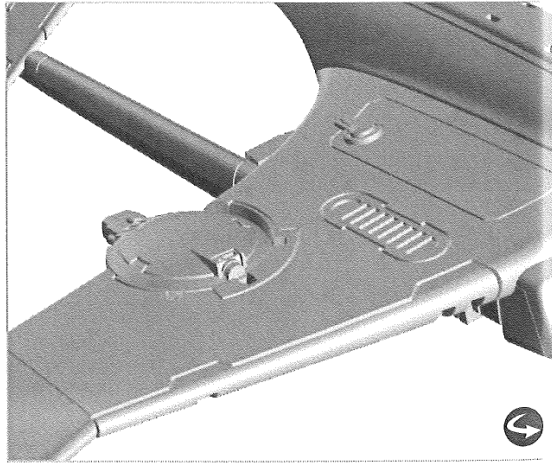
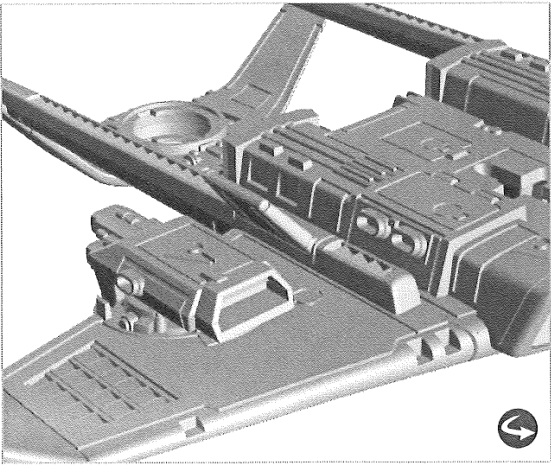
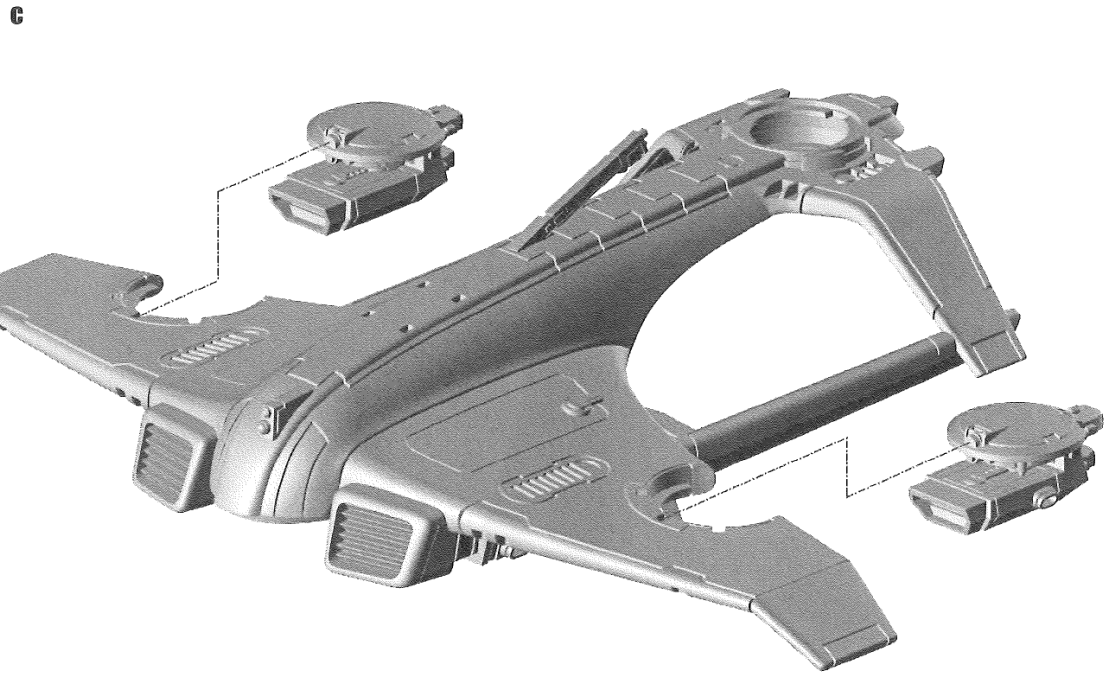
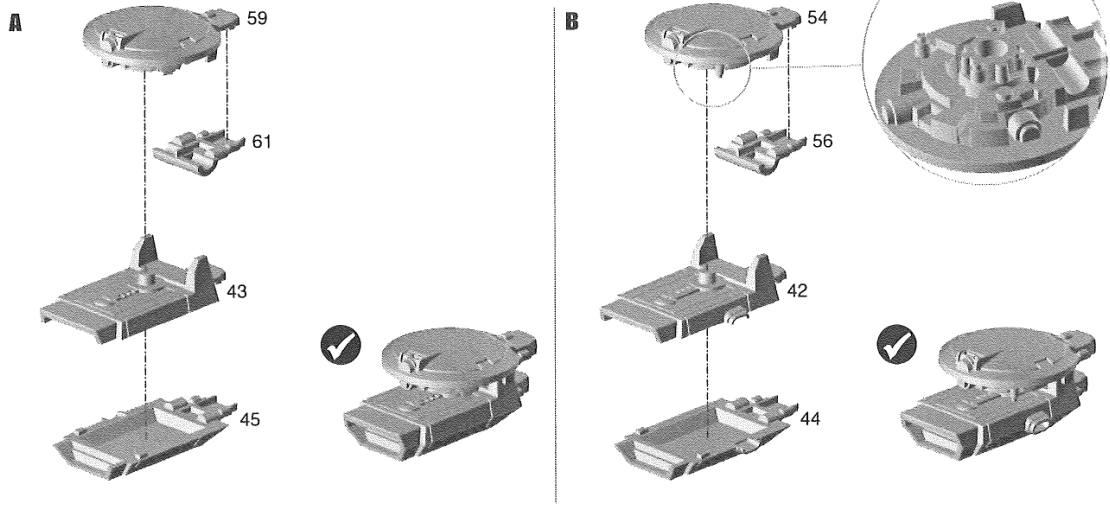

12

A

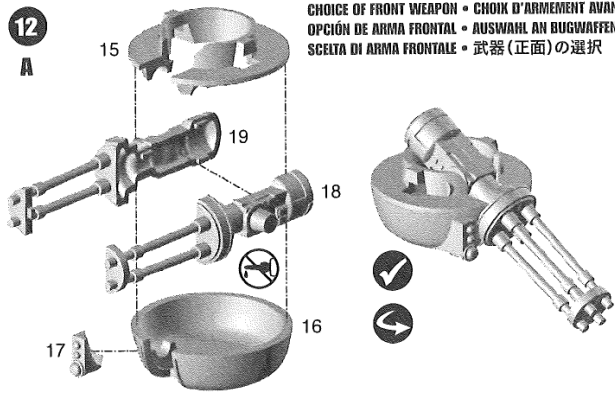

B

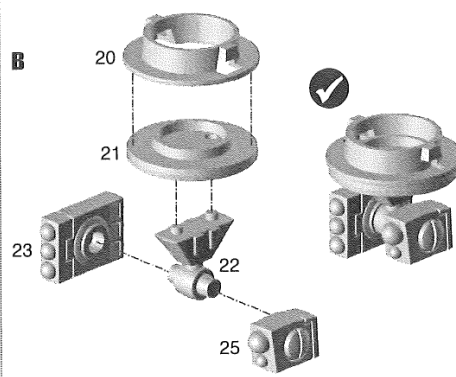

C

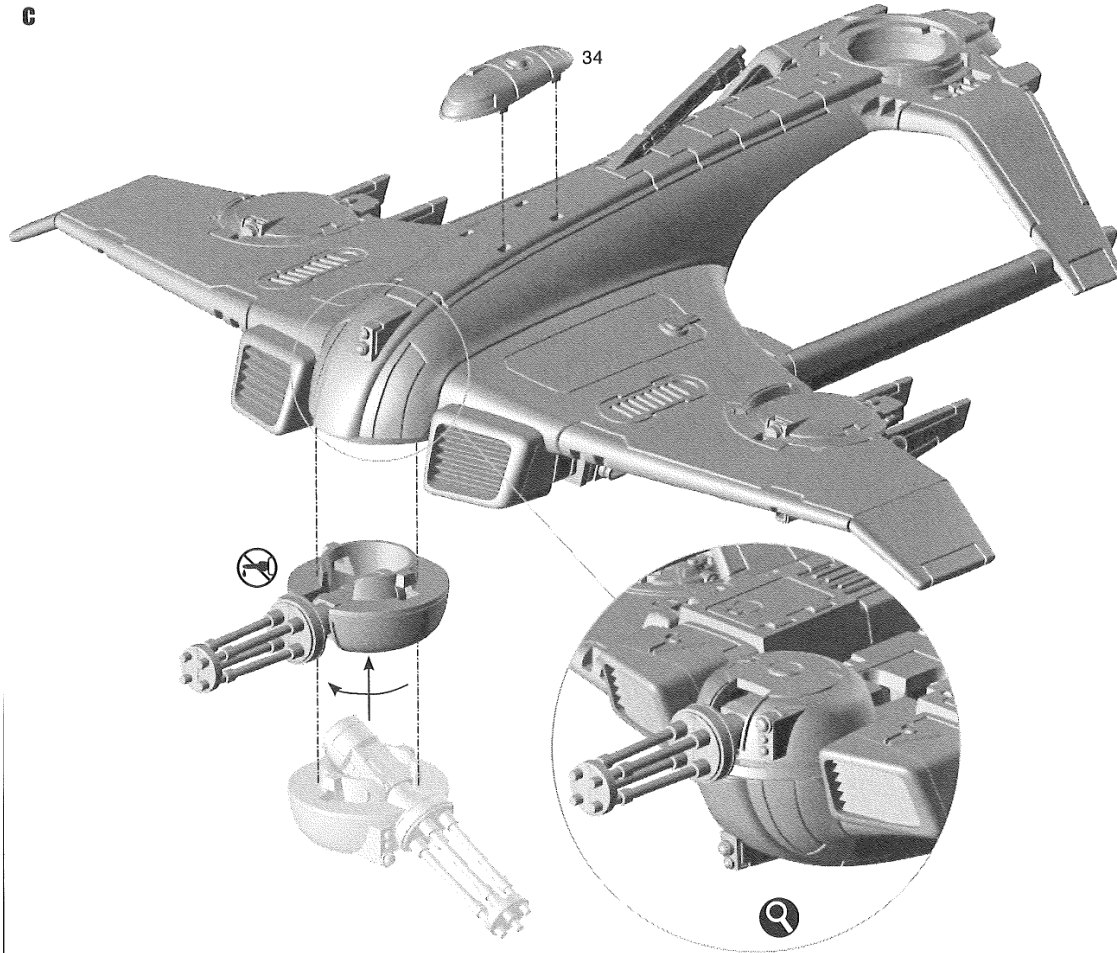

✓



13 MAIN WEAPON • ARMEMENT ARRIÈRE • ARMA PRINCIPALE
HAUPTWAFFE • ARMA PRINCIPALE • 主要武器

A

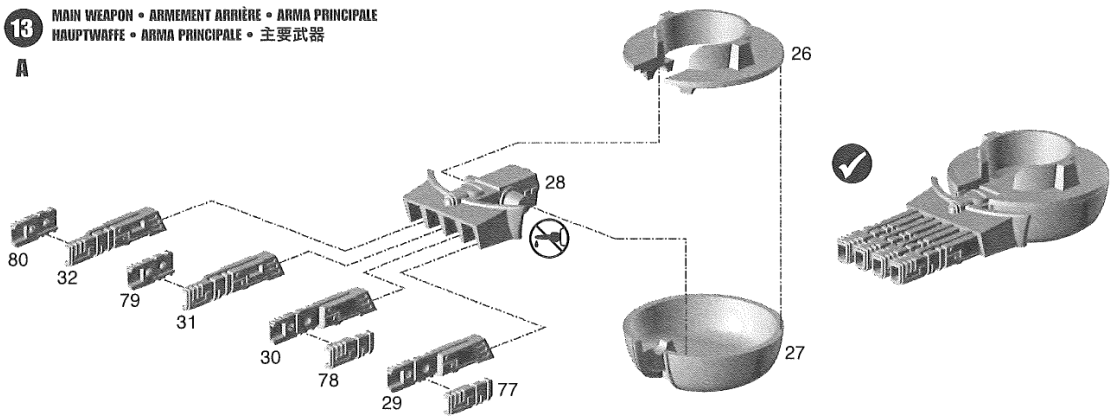

B

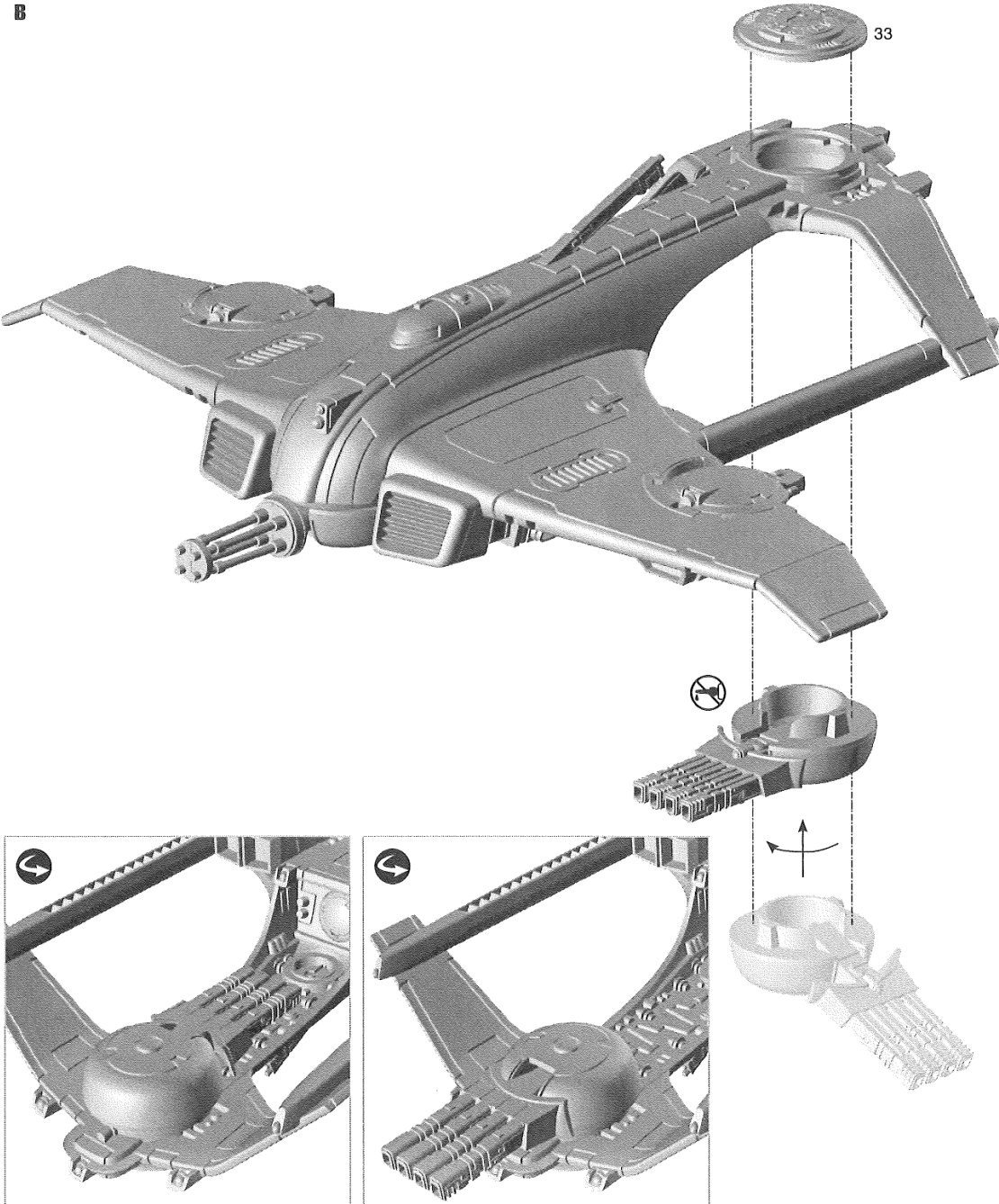

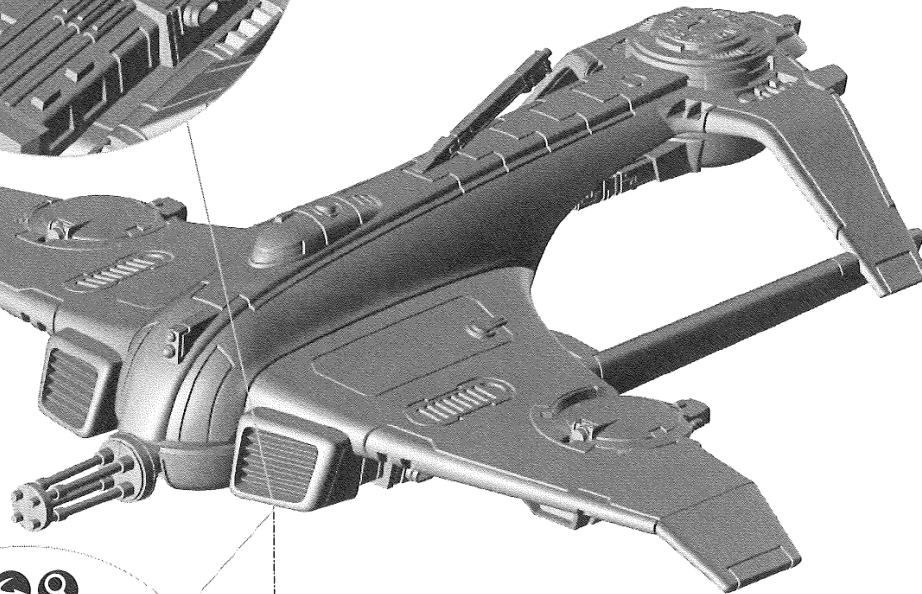
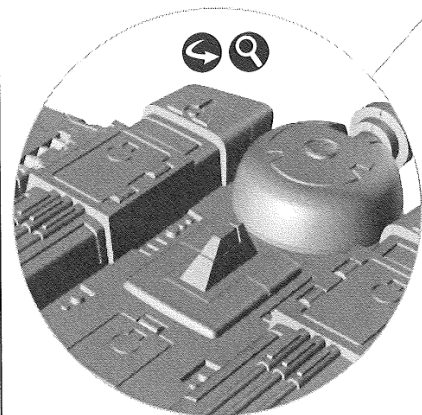
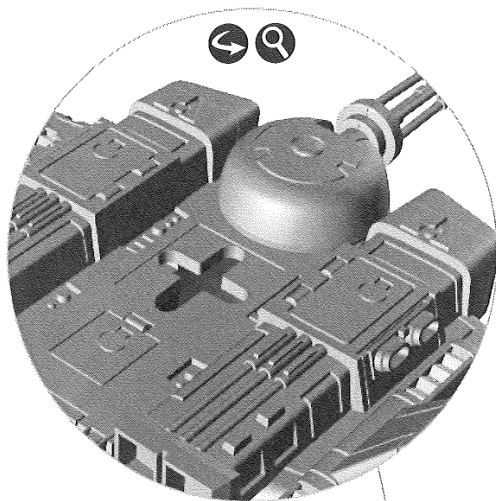

! If you do not use the flying stand attach the cover hatch instead
 Si vous n'utilisez pas le socle volant, placez le cache
 Si no utilizas piezas de voladores pega la tapa de la escotilla
 Wenn du nicht das Flugbase benutzt, bringe stattdessen den Lukendeckel an
 Se non utilizzi il supporto per modelli volanti, incolla il portellone
 フライイングスタンドを使用しない場合は、代わりにカバーハッチを取り付ける

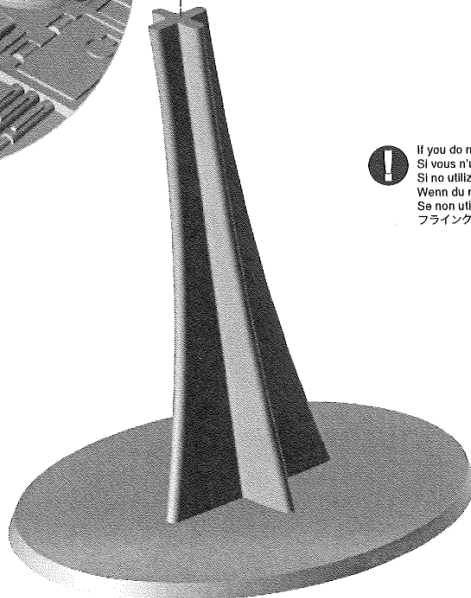

RAZORSHARK STRIKE FIGHTER

CHASSEUR RAZORSHARK

CAZA TIBURÓN LANZA

KLINGENHAI-JAGDBOMBER

CACCIA D'ASSALTO RAZORSHARK

レイザーシャーク・ストライクファイター

